

3DLevelScanner

LEVEL SENSOR

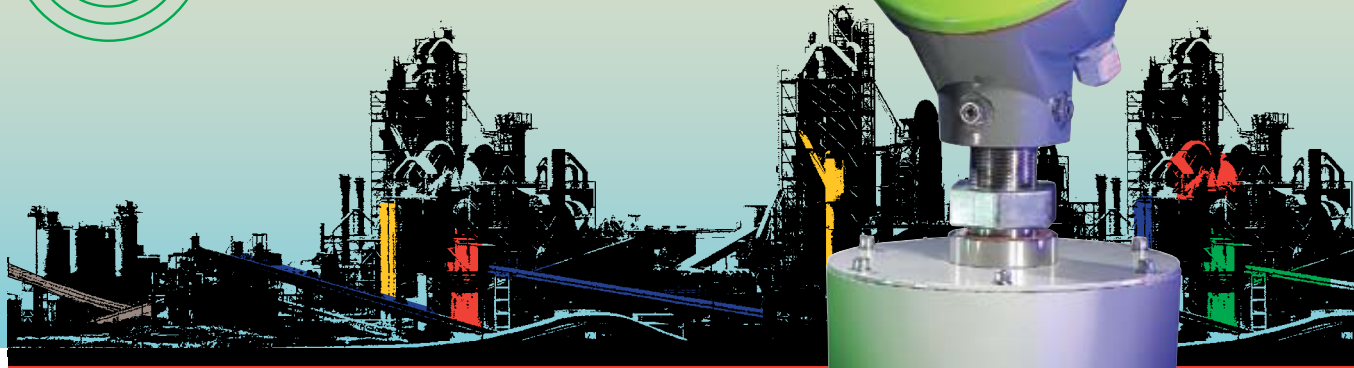

TECHNICAL DATA SHEET

The Vision of 3D Level Measurement

The **APM 3DLevelScanner™** provides an innovative measurement method that takes the guesswork out of measuring the level, volume and mass of materials inside a silo or open bin.



Theory of operation

The APM 3DLevelScanner is an innovative new family of devices that measure continuous level, volume and mass of materials inside a silo or open bin.

The 3DLevelScanner employs a 2-dimensional array beam-former to transmit low frequency pulses and to receive and record echoes of the pulses from the contents of the silo, bin or other container. The device's Digital Signal Processor samples and analyzes the received signals. From the estimated times of arrival and directions of received echoes, the processor generates a 3-dimensional image of the surface that can be displayed on a remote screen. This unique device can then accurately determine the volume and mass of material, enabling an unrivaled degree of process measurement and inventory control.

3-D Mapping

- The 3DLevelScanner can **measure the level, volume and mass of materials in new applications that prior technology could not reach**. It measures practically any kind of material stored in practically an unlimited variety of containers, including large open bins, bulk solid storage rooms and warehouses, mapping loads that randomly form over time inside silos, and many other previously inaccessible challenging applications.
- 3-dimensional mapping delivers **true and absolute surface level, volume and mass values** inside a silo or open bin with accuracy like never before.

3D mapping of the surface area

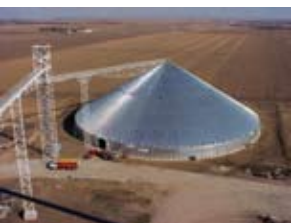
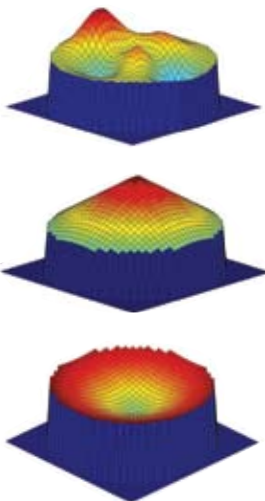

Remote display
4-wire

Display in 5 languages:
English, German, Spanish, French, Italian

Easy navigation.
LCD with 4- button operation

Same housing for all versions.
(Ex and non-Ex)

Various antenna types and materials
for all applications

Key Specifications

Preferred application:	Solids
Measuring range:	70 m
Process fitting:	Thread, flange
Process temperatures:	-40 to +80°C (-40 to +176°F)
Process pressure:	-0.2 to 1 bar (-2.9 to 14.5 Psi)
Signal Output:	4-wire 4...20mA/HART/RS-485/Modbus
Emitting Frequency:	3.5 KHz to 10 KHz

Materials, non-wetted parts

Housing	Alu-die casting powder coated
Inspection window in housing cover	Polycarbonate
Antenna	Alu
Flange	Steel

Weight

9.9 kg ...11.4 kg	Depending on the flange size and housing (Alu, SS)
-------------------	--

Output variable

Output signal	4 ...20mA/HART/RS485/Modbus
Resolution	1.6 uA
Fault signal	Current output unchanged, 22mA, >3.6 mA (adjustable)
Current limitation	22 mA

Load

4-wire sensor	Max. 500 Ohm
Integration time	0 ...9999 s, adjustable

Ambient conditions

Ambient, storage and transport temperature	-40 ...85°C (-40...+185°F)
--	----------------------------

Process conditions

Vessel pressure	-0.2 ... 1 bar (-2.9 ... 14.5 Psi or -20 ... 100 kPa)
-----------------	---

Process temperature

Measured on the process fitting	-40 ...80°C (-40 ...176°F)
Vibration resistance	Mechanical vibrations with 2g and 5 ...200 Hz

Electromechanical data

Cable entry/plug	1 x cable entry M20x1.5 (cable-Ø 5 ...9mm),
	1 x blind stopper M20x1.5
	Or
	1 x closing cap 1/2NPT, 1 x blind stopper 1/2NPT

Display panel

LCD	4 lines x 20 characters
Adjustment elements	4 keys
Protection (inside sensor without cover)	IP40

Power supply – 4-wire instrument 4...20 mA / HART

Supply voltage	20 ...32 VDC
Power consumption	max 4VA; max 2.1 W

Electrical protective measures

Protection	IP 66/67
------------	----------

Approvals

ATEX	ATEX II 1/2D, Ex ibD/iaD 20/21 T110°C
FM	FM Intrinsic safety (pending)
CSA	cCSAus Intrinsic safety (pending)
IECM	IEC EEx ia IIC T6 (pending)

CE

EMC	
Emission	EN 61326: 1997 (class B)
Susceptibility	EN 61326: 1997/A1: 1998
NSR (73/23/EWG)	EN 61010-1: 2001

FCC

Conformity	to part 15 of the FCC regulations FCC 47 CFR part 15:2007, subpart B, class A
------------	--

Measurement characteristics

Temperature measurement accuracy	0.5°K
Frequency	3.5-10 kHz
Beam angle with horn antenna	30 - 70 degrees
Interval	>2 s (dependent on the parameter adjustment)
Adjustment time	>3 s (dependent on the parameter adjustment)

Accuracy

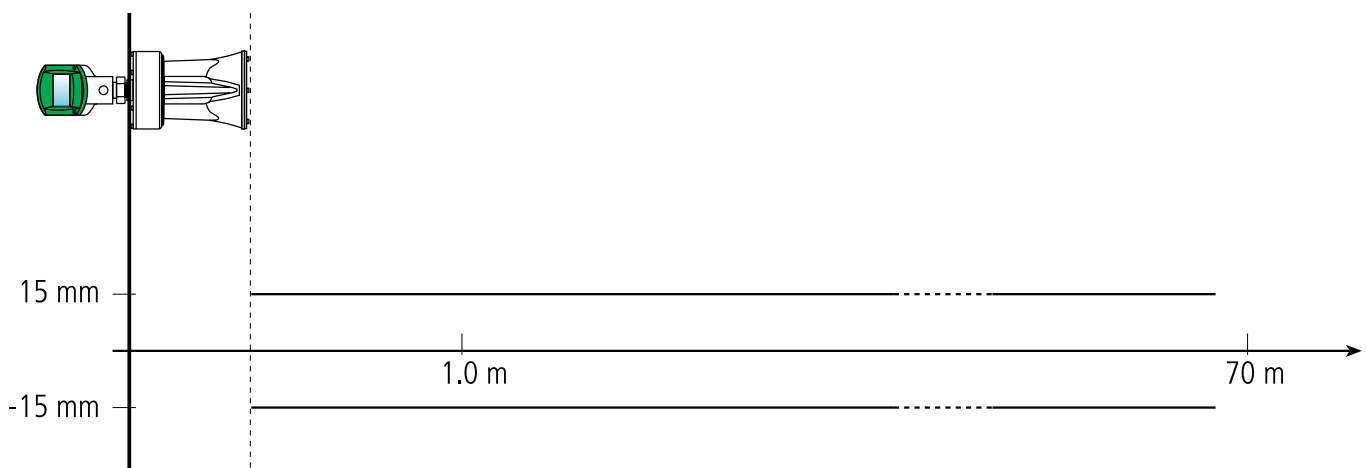

3DLevelScanner with horn antenna in flange version

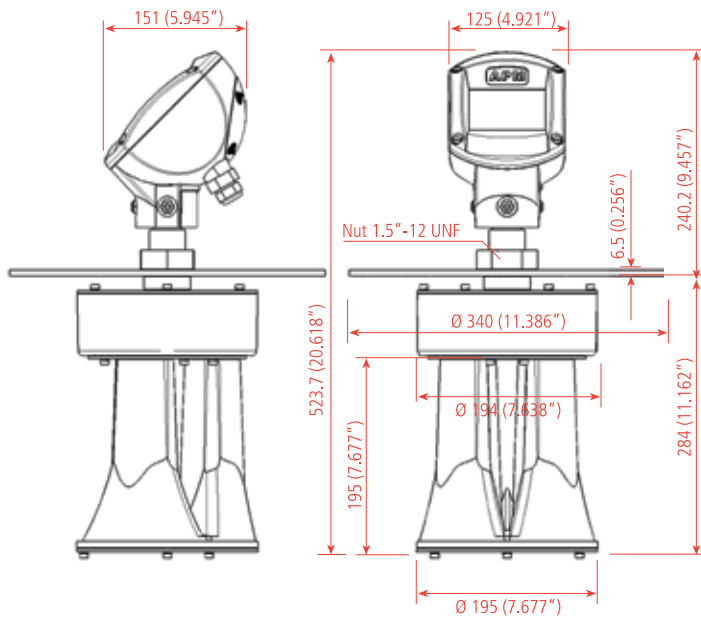

3DLevelScanner with horn antenna in threaded version

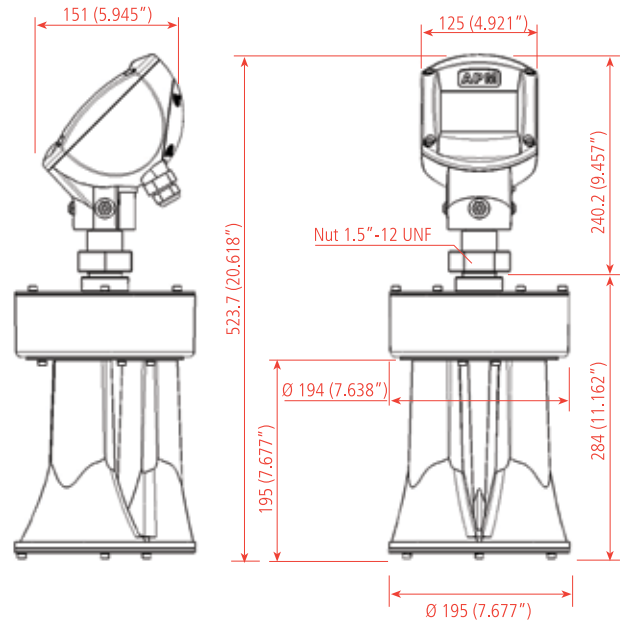

3DLevelScanner Housing

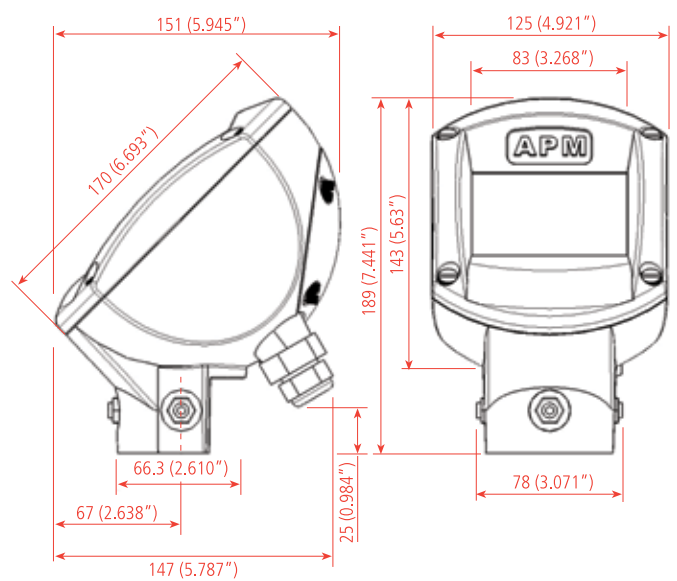

Dimension in mm (inch)

General Requirements

The power supply range can differ depending on the instrument version. See the Technical Data section for full details.

In hazardous areas you should take note of the appropriate regulations, conformity and type approval certificates of the sensors and power supply units.

Power Supply

4 ...20 mA/HART 4-wire

Power supply and signal current are carried on two separate connection cables.

Connection Cable

An outer cable diameter of 5 ...9 mm ensures the seal effect of the cable entry. If electromagnetic interference is expected, we recommend the use of screened cable for the signal lines.

Wiring Plans

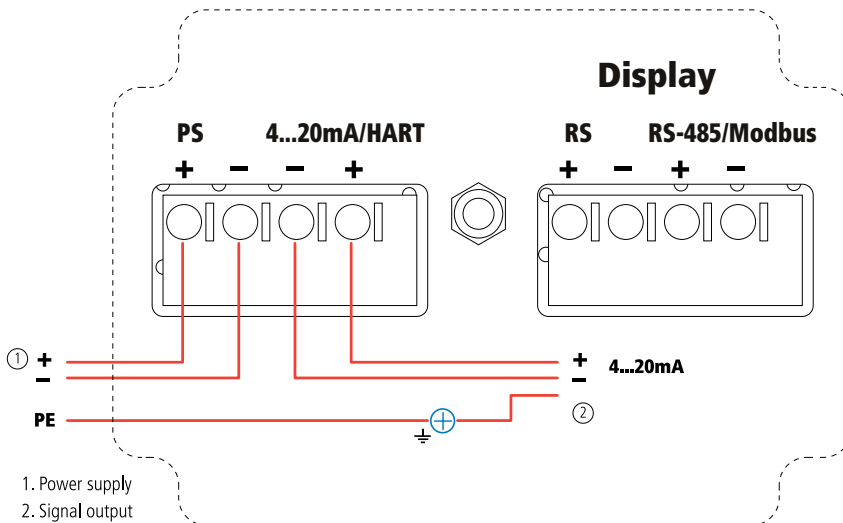

The 3DLevelScanner can be set up and operated using one of the following:

- The LCD panel
- HART handheld
- An adjustment software tool (3DLevel Manager)

Adjustment Using the LCD Panel

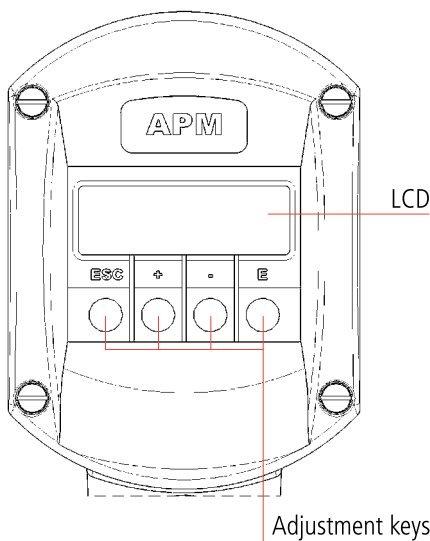

-	Navigate Downwards in the selection list; Shifts to the Right within a function
+	Navigate Upwards in the selection list; Edit Numeric Value within a function†
Esc	Navigate to the Left within a function group; Press Esc for 3 sec to go back to the basic screen
E	Navigate to the Right within a function group; Confirmation
+ and E	Increase contrast settings of the LCD
- and E	Decrease contrast settings of the LCD
+ and - and E	Hardware lock/unlock

After a hardware lock, operation of the instrument via display or remote communication is not possible.

The hardware can only be unlocked via the display, and an unlock parameter must be entered to do so.

The display continues – uninterrupted.

When all three buttons are pressed the display writes: "Hardware locked".

When all three buttons are pressed again the display asks for "unlock parameter".

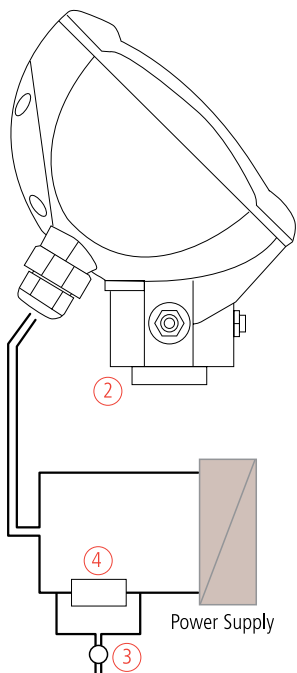

1. RS-232/USB connection
2. 3DLevelScanner
3. HART adapter cable
4. HART Resistance -250 Ohm

Adjustment using the 3DLevel Manager Software Tool

The 3DLevelScanner can be configured and operated via APM's software tool (3DLevel Manager). Connect the 3DLevelScanner according to the following diagram.

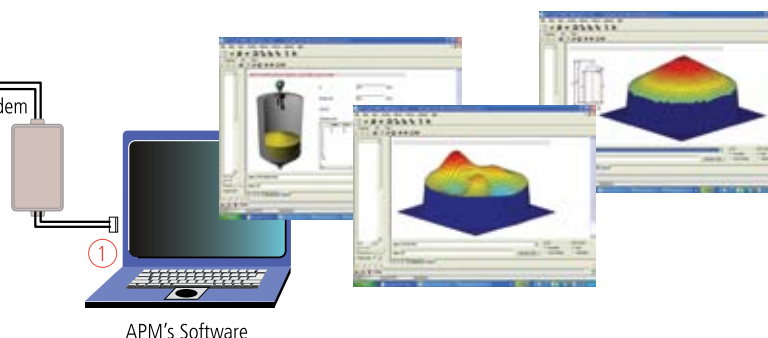

Type

S For solid applications

M For solid applications with mapping capabilities

MV For solid applications with mapping capabilities and visualization graphics tool

Approvals

XX Without

DX ATEX II 1/2D, Ex ibD/iaD 20/21 T110°C

Version / Material

B With horn antenna @195mm/ALU

Process connection

GD Thread 1.5" –12 UNF

FD Flange DN200/PP

AD Flange 8" 150 b RF

FE Flange DN200/SS

FF Flange DN250/PP

FG Flange DN250/SS

AE Flange 8" 150b RF, ANSI/SS

AF Flange 10" 150b RF, ANSI/SS

Electronics

V 4 ...20mA/HART – 4-wire/RS485/Modbus

Cable entry / Plug connection

M M20x1.5 / without

N 1/2NPT / without

Internal display

A Yes

External (remote) display

A Yes

B No

3DLevelScanner



APM Automation Solutions Ltd

24 Habarzel Street
Tel Aviv 69710, Israel
Tel: +972 3 6488891
Fax : +972 3 6488892
info@apm-solutions.com
www.apm-solutions.com



Represented by

© 2005 APM Automation Solutions Ltd. All rights reserved.
Information in this document is subject to change without notice.
APM Automation Solutions Ltd. and the APM 3DLevelScanner are
trademarks of APM Automation Solutions Ltd.

SPEC000100 Rev. E