

# 3D LevelScanner S

## PRODUCT INFORMATION

Level measurement in  
solid applications

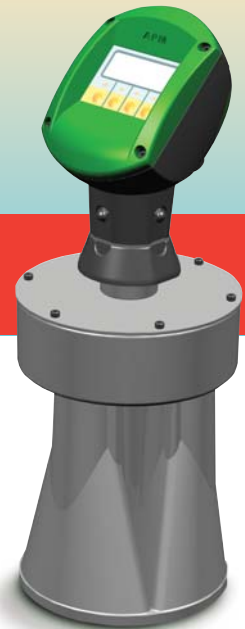

# Table of contents

<b>1</b>	<b>OVERVIEW .....</b>	<b>3</b>
1.1	THEORY OF OPERATION.....	3
1.2	WIDE APPLICATION RANGE.....	3
1.3	ADVANTAGES.....	3
1.4	KEY SPECIFICATIONS.....	3
<b>2</b>	<b>MOUNTING INFORMATION .....</b>	<b>4</b>
2.1	MEASURING RANGE .....	4
2.2	PRESSURE.....	4
2.3	INSTALLATION LOCATION .....	4
2.4	MOUNTING DIRECTION.....	6
2.5	SOCKET .....	7
2.6	SENSOR ORIENTATION.....	8
2.7	INFLOWING MATERIAL .....	8
<b>3</b>	<b>ELECTRICAL CONNECTION AND WIRING.....</b>	<b>9</b>
3.1	GENERAL REQUIREMENTS .....	9
3.2	POWER SUPPLY .....	9
3.3	DATA CABLES .....	9
3.4	WIRING PLANS .....	10
<b>4</b>	<b>OPERATION.....</b>	<b>11</b>
4.1	ADJUSTING THE 3DLEVELSCANNER M USING THE LCD PANEL.....	11
4.2	ADJUSTING THE SCANNER USING THE SOFTWARE TOOL.....	13
<b>5</b>	<b>DIMENSIONS .....</b>	<b>14</b>
<b>6</b>	<b>TECHNICAL DATA .....</b>	<b>17</b>
6.1	AMBIENT CONDITIONS .....	18
6.2	PROCESS CONDITIONS.....	18
6.3	PROCESS TEMPERATURE.....	18
6.4	ELECTROMECHANICAL DATA.....	18
<b>7</b>	<b>ORDERING INFORMATION .....</b>	<b>20</b>

## Table of Figures

<i>Figure 1: Measuring range</i> .....	4
<i>Figure 2: Mounting on arched vessel tops</i> .....	5
<i>Figure 3: 0° Sticker location</i> .....	6
<i>Figure 4: Recommended socket mounting</i> .....	7
<i>Figure 5: Inflowing material</i> .....	8
<i>Figure 6: Connection HART 4-wire</i> .....	10
<i>Figure 7: 3DLevelScanner S front panel LCD</i> .....	11
<i>Figure 8: Software Tool connection</i> .....	13
<i>Figure 9: 3DLevelScanner S with horn antenna in threaded version</i> .....	14
<i>Figure 10: 3DLevelScanner S with horn antenna in flange version</i> .....	15
<i>Figure 11: 3DLevelScanner S housing</i> .....	16
<i>Figure 12: Voltage diagram</i> .....	17
<i>Figure 13: Accuracy</i> .....	19

<p><b>Take note of safety instructions for Ex areas</b></p>		<p>Please note the Ex specific safety information for installation and operation in Ex areas which you will find on our homepage on <a href="http://www.apm-solutions.com/services">www.apm-solutions.com/services</a> and which comes with the appropriate instrument. In hazardous areas you should take note of the appropriate regulations, conformity and type approval certificates of the sensors and power supply units. The sensors must only be operated in intrinsically safe circuits. The permissible electrical values are stated in the certificate.</p>
---	---	---

# 1 Overview

## 1.1 Theory of Operation

The APM 3DLevelScanner™ is an innovative new family of devices that continuously measure level, volume and mass of materials inside a silo or an open bin.

The 3DLevelScanner employs a 2-dimensional array-beam former to transmit low frequency pulses and receive echoes of the pulses from the contents of the silo, bin or any other container. The device's digital signal processor samples and analyzes the received signals. The processor uses the time and direction parameters of the received echoes to generate a 3-dimensional image of the surface, which can be displayed on a remote monitor. The system can accurately determine the volume and mass of material, enabling an unrivaled degree of process measurement and inventory control.

## 1.2 Wide Application Range

The 3DLevelScanner S measures practically any kind of solid material, stored in practically unlimited variety of containers, including large open bins, bulk solid storage rooms and warehouses, mapping loads that randomly form over time inside silos, and many other challenging applications that were not possible until now. The sensor can measure ranges of up to 70 m (230 ft) and generate 3D maps of the surface.

## 1.3 Advantages

- **Practice-oriented device versions** - The 3DLevelScanner S is available with both thread and flange fittings.
- **Unaffected by content properties** - Fluctuations in content composition or even complete content changes do not influence the measuring result. No special adjustment or calibration is necessary.
- **Service and maintenance-friendly** - Thanks to the non-contact measuring principles, the 3DLevelScanner S is particularly easy to service and maintain.

## 1.4 Key Specifications

Preferred application:	Solids
Measuring range:	70 m
Process fitting:	Thread, flange
Process temperatures:	-40 <sup>0</sup> to +80 <sup>0</sup> C (-40 <sup>0</sup> to +176 <sup>0</sup> F)
Process pressure:	-0.2 to 1 bar (-2.9 to 14.5 Psi)
Signal output:	4-wire 4...20mA/HART/RS485/Modbus
Emitting Frequency:	3.5 kHz to 10 kHz

## 2 Mounting Information

### 2.1 Measuring Range

The reference plane of the sensor measuring range is the seal surface of the thread or the lower side of the flange. All information regarding the measuring range as well as the internal signal processing relates to the reference plane.

**NOTE:**

If the container content reaches the antenna, buildup could form on it over time and cause measurement errors.

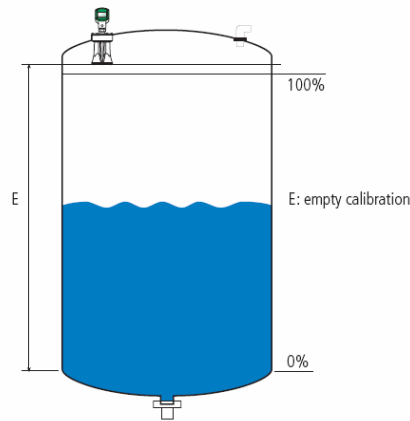

**Figure 1: Measuring range**

### 2.2 Pressure

The process fitting must be sealed if there is low pressure in the vessel. Before use, verify that the seal material is resistant to the medium. The maximum permissible pressure is stated in *Technical data, page 17*, and on the type label of the sensor.

### 2.3 Installation Location

When mounting the 3DLevelScanner S, a distance of at least 300 mm from the vessel wall should be maintained. If the 3DLevelScanner S is installed in the center of the vessel, multiple echoes can occur.

---

**Note:** It's recommended **not** to install the 3DLevelScanner S in the center of the silo.

---

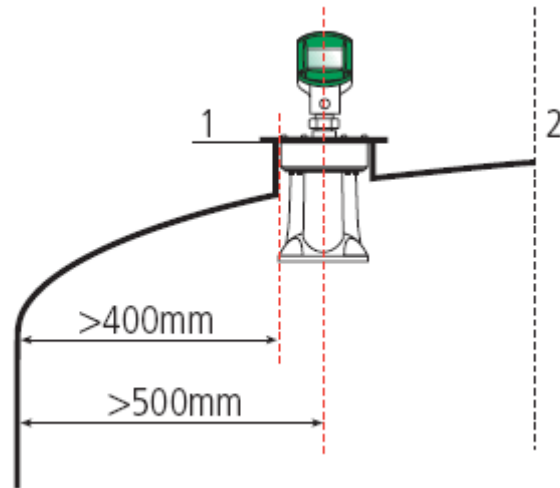

**Figure 2: Mounting on arched vessel tops**

1. Reference plane
2. Vessel center or symmetry axis

If this distance cannot be maintained, a false echo storage should be carried out. This applies particularly if buildup of residue on the vessel wall is expected.

---

**Note:** It is very important to use "range of mapping" right after installation, in order to map all false echoes. The results are better when the silo is empty.

---

## 2.4 Mounting Direction

The mounting direction is indicated by a sticker labeled  $0^0$  on the instrument (see image below). The  $0^0$  must point to the center of the vessel (including square vessels and open bins).

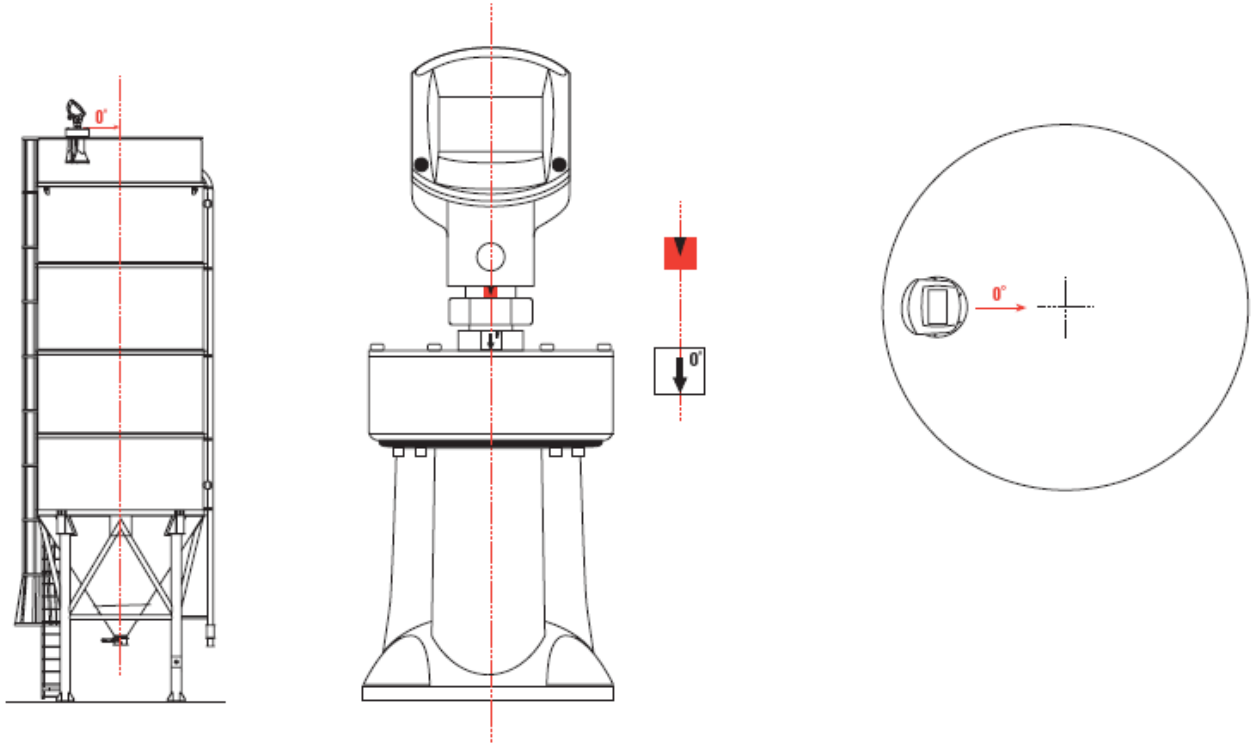

**Figure 3: Viewing Point ( $0^0$  Sticker location)**

---

**Note:** The direction of the mounting has no influence on 3DLevelScanner S (it only matters in M/MV versions). However, it is recommended to mount it correctly in any case for future upgrade to M or MV versions.

---

## 2.5 Socket

Socket pieces should be positioned so that the antenna end protrudes at least 10 mm (0.4 inch) out of the socket.

**Important Note:** Rails/frames should never interfere with the 60° beam angle transmitted and received (see figures below).

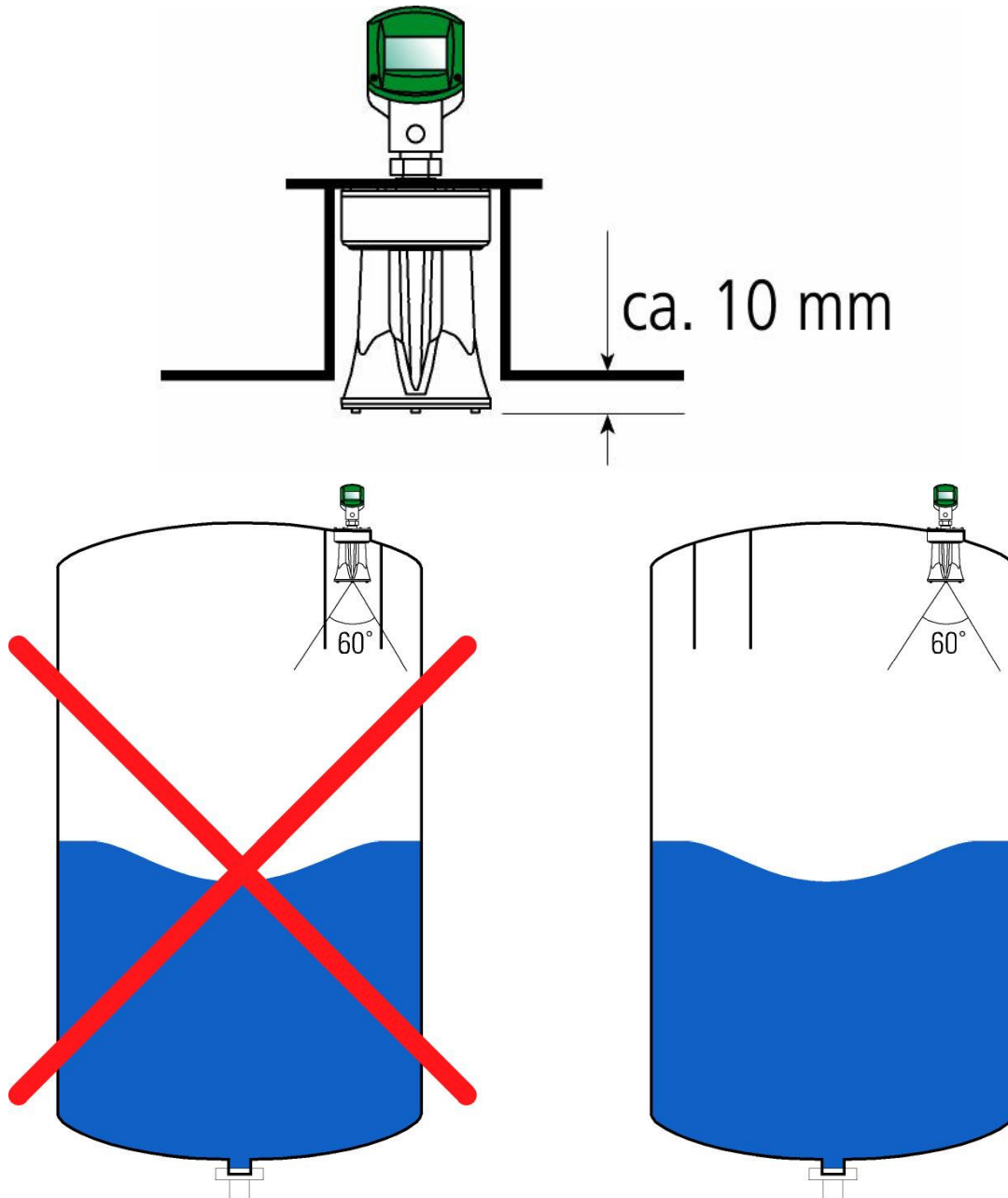

**Figure 4: Recommended socket mounting**

## 2.6 Sensor Orientation

The sensor will generate optimal performance if it is located halfway between the wall and the center of the silo.

## 2.7 Inflowing Material

Do not mount the devices in or above the filling stream. The optimal position is as far away from the inflowing material.

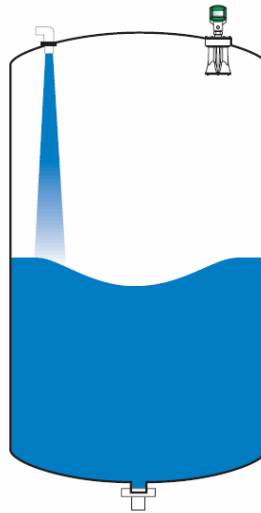

**Figure 5: Inflowing material**

## 3 Electrical Connection and Wiring

### 3.1 General Requirements

The power supply range can differ depending on the device version. See the Technical data for full details.

In hazardous areas note should be taken of the appropriate regulations, conformity and type approval certificates of the sensors and power supply units.

### 3.2 Power Supply

- **24 VDC**

The 3DLevelScanner is supplied with 24 VDC from 2 wires cable.

### 3.3 Data Cables

- **4...20 mA/HART 4-wire**

Power supply and signal current are carried on two separate connection cables. The HART cable should be 2W shielded twisted pair.

- **RS485**

Standard RS485 serial communication, 2W cable, shielded and twisted.

Modbus RTU communication, 2W cable, shielded and twisted

### 3.4 Wiring Plans

4...20mA/  
HART 4-wire/  
RS485

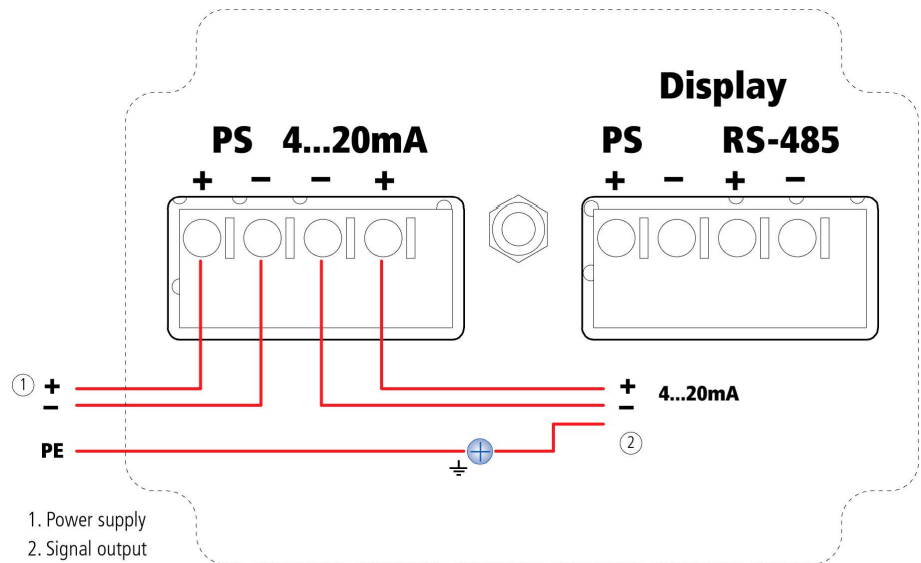

Figure 6: Connection HART 4-wire

## 4 Operation

The 3DlevelScanner S can be set up and operated using one of the following:

- The LCD panel
- A HART handheld device
- GSM communication using 3DLink Pro
- An adjustment software tool

### 4.1 Adjusting the 3DlevelScanner S Using the LCD Panel

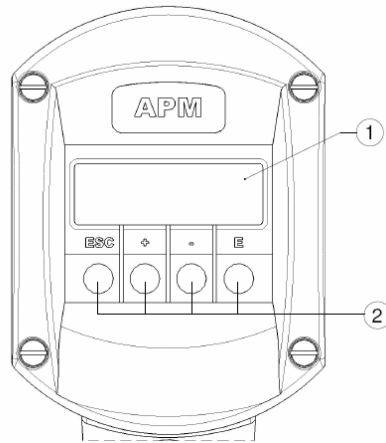

**Figure 7: 3DlevelScanner S front panel LCD**

1. LCD
2. Adjustment Keys

**Adjustment keys:**

- Navigates downwards in the selection list
- Shifts to the right within a function



- Navigates upwards in the selection list
- Edit numeric values within a function



Navigates to the Left within a function group; Press **Esc** for 3 sec to go back to the default screen



- Navigates to the right within a function group;
- Confirmation

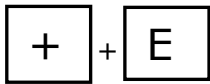

Increases the contrast of the LCD

Simultaneously

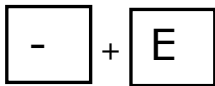

Decreases the contrast of the LCD

Simultaneously

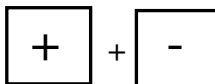
**Hardware lock/unlock**

After a hardware lock, operation of the device via display or remote communication is not possible.

The hardware can only be unlocked via the display, and an unlock parameter must be entered to do so.

The display continues – uninterrupted.

When all three buttons are pressed the message “Hardware locked” is displayed.

When all three buttons are pressed again, the message “unlock parameter.” Appears. Enter the unlock parameter (100) and confirm by pressing E.

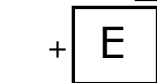

Simultaneously

## 4.2 Adjusting the Scanner Using the Software Tool

The 3DLevelScanner S can be configured and operated via APM's Software Tool. Connect the 3DLevelScanner S according to the following diagram:

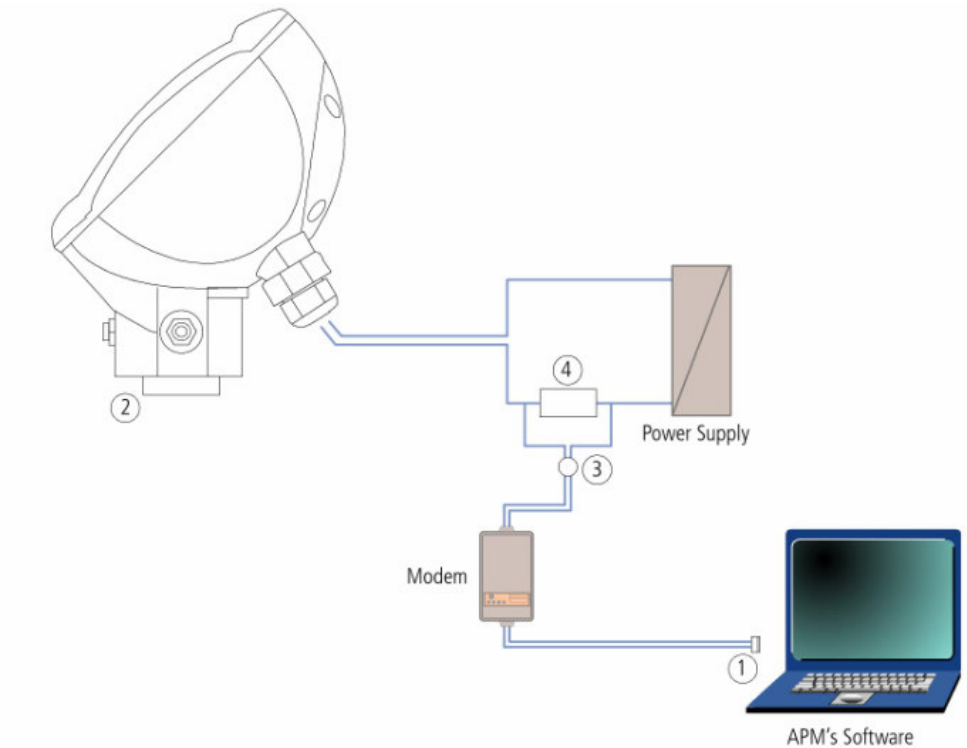

**Figure 8: Software Tool connection**

1. RS-232/USB connection
2. 3DLevelScanner S
3. HART Adapter cable
4. HART Resistance—250 ohm

---

For specific instructions on adjusting parameters with APM's software tool, please see the "APM 3DLevel Manager Software Operating Instructions" manual.

---

### 4.2.1 Parameter adjustment with APM's Software Tool

Further setup steps are described in the operating manual *APM 3DLevel Manager software operating instructions* included with each CD, which can also be downloaded from our Web site.

## 5 Dimensions

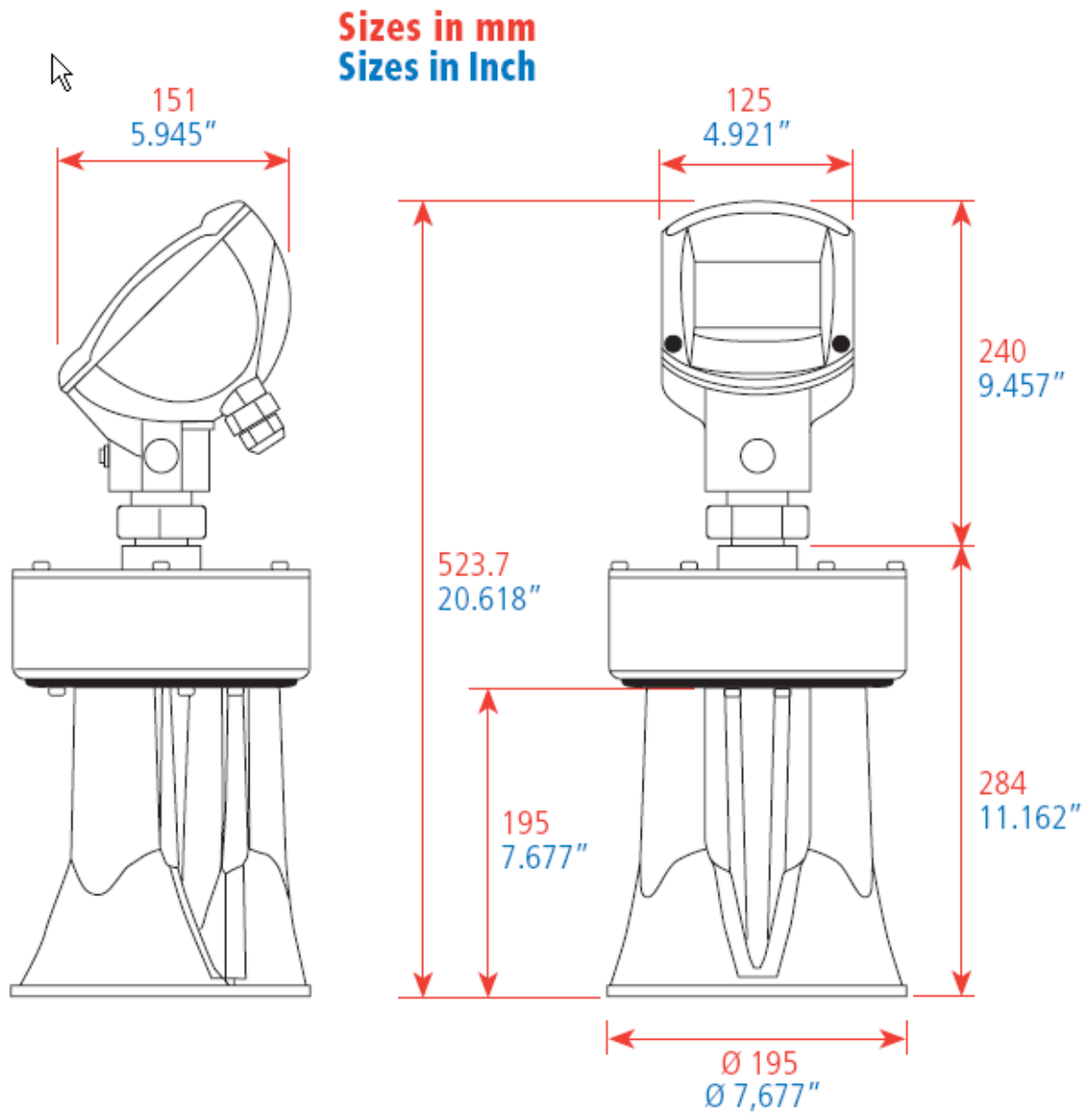

**Figure 9: 3DLevelScanner S with horn antenna in threaded version**

Dimensions are in mm (inch).

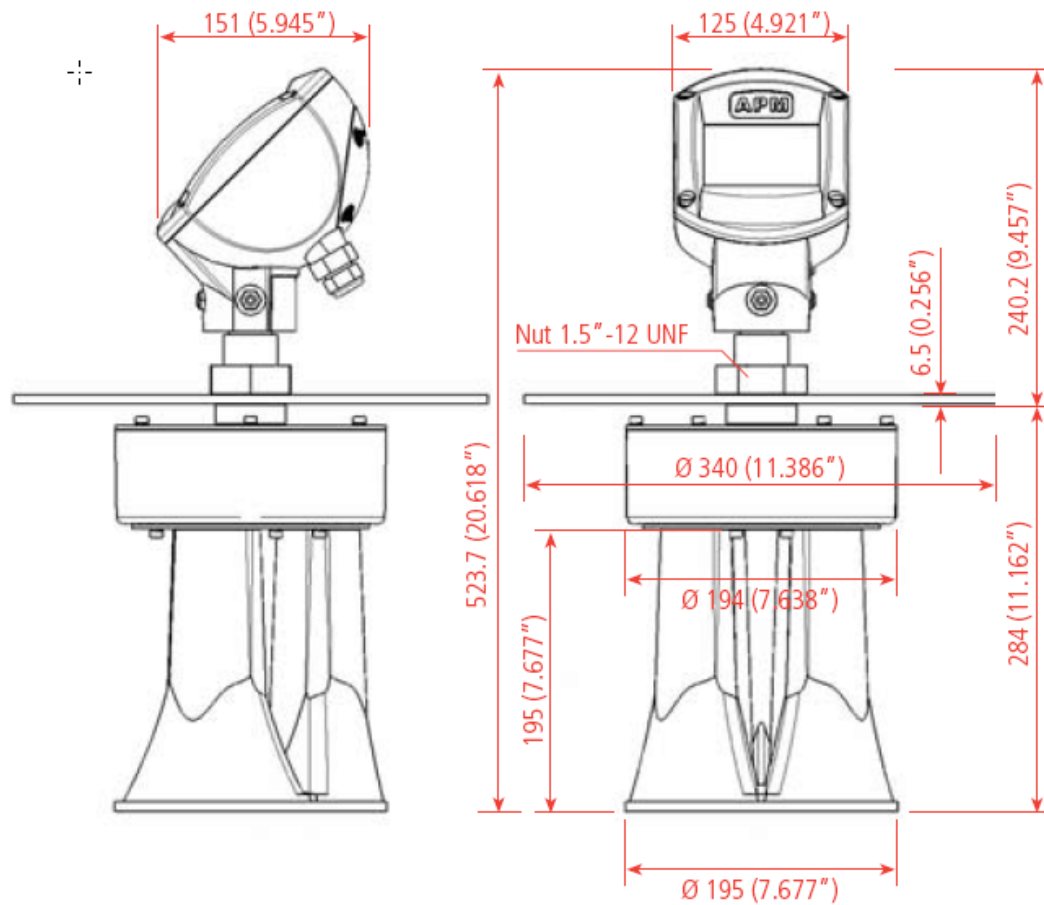

**Figure 10: 3DLevelScanner S with horn antenna in flange version**

Dimensions in are mm (inch).

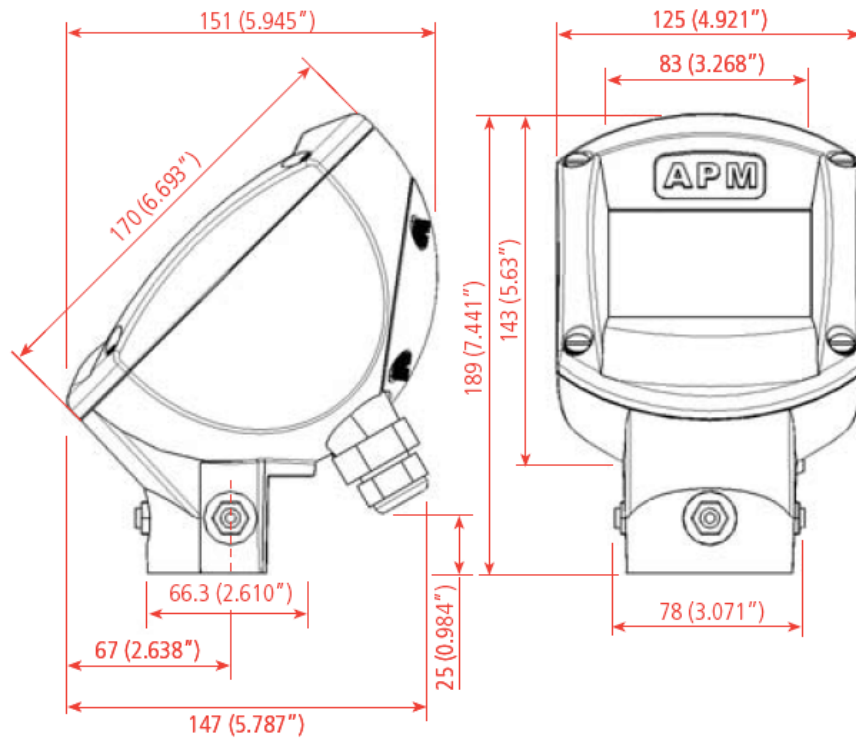

**Figure 11: 3DLevelScanner S housing**

Dimensions are in mm (inch).

## 6 Technical data

### Materials, non-wetted parts

Housing	Alu-die casting powder coated.
Inspection window in housing cover	Polycarbonate
Antenna	Alu
Flange	SS
Ground terminal	Stainless steel 1.4571/1.4435

### Weight

9.9 kg ...11.4 kg	Depending on the flange size and housing (Alu, SS)
-------------------	--

### Output variable

Output signal	4...20mA/HART/RS485/Modbus RTU
Resolution	1.6 $\mu$ A
Fault signal	Current output unchanged, 22 mA, >3.6 mA (adjustable)
Current limitation	22mA

### Load

4-wire sensor	See load diagram
Integration time	0...999 s, adjustable

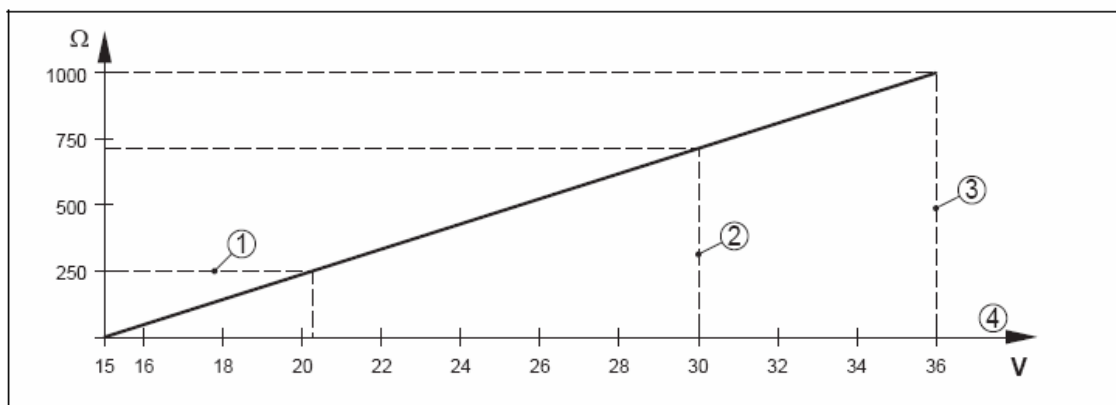

Figure 12: Voltage diagram

1. HART Load
2. Voltage Limit EEx ia device
3. Voltage limit non-Ex/Exd ia device
4. Supply Voltage

### 6.1 Ambient conditions

Ambient, storage and transport temperature: -40...85°C (-40...+185°F)

### 6.2 Process conditions

Vessel pressure: -0.2 ... 1 bar  
(-20...100 kPa or -2.9 ... 14.5 Psi)

### 6.3 Process temperature

Measured on the process fitting: -40...80°C (-40...176°F)

Vibration resistance: Mechanical vibrations with 4g and 5...100 Hz

### 6.4 Electromechanical data

Cable entry/plug: 1 x cable entry M20x1.5 (cable-Ø 5...9mm), 1 x blind stopper M20x1.5

or

1 x closing cap ½NPT, 1xblind stopper ½NPT

#### Display panel

LCD	4 lines x 20 characters
Adjustment elements	4 keys
Protection (inside sensor without cover)	IP40

#### Power supply – 4-wire device

##### 4...20 mA/HART

Supply voltage	20...30 VDC
Power consumption	max 4VA; max 2.1 W

#### Electrical protective measures

Protection	IP 66/67
------------	----------

#### Approvals

ATEX	ATEX II 1/2D Ex iaD/ibD 20/21 T110 °C
FM	FM Intrinsic safety (pending)
CSA	CSA Intrinsic safety (pending)
IECM	IEC EEx ia IIC T6 (pending)

#### CE

EMC	
- Emission	EN 61326: 1997 (class B)
- Susceptibility	EN 61326:1997/A1: 1998
NSR (73/23/EWG)	EN 61010-1: 2001

#### Measurement characteristics

Temperature measurement accuracy	0.5° K
----------------------------------	--------

Frequency	3-5 kHz
Beam angle with horn antenna	30 degrees
Interval	>2 s (dependent on the parameter adjustment)
Adjustment time	>3 s (dependent on the parameter adjustment)

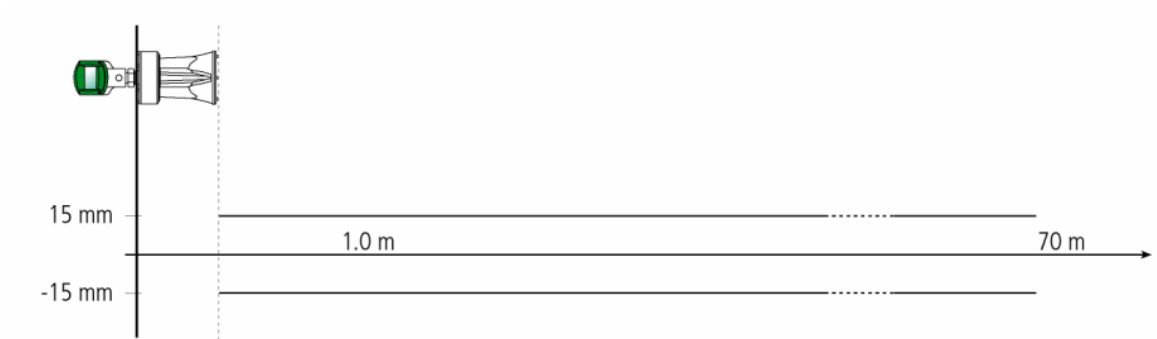
**Accuracy (see diagram)****Figure 13: Accuracy**

# 7 Ordering Information

## Approvals

XX Without

DX ATEX II 1/2D Ex iaD/ibD 20/21 T110 °C

## Version/Material

B With horn antenna@195mm /PP

## Process Connection

GD 1.5"-12 UNF

FD Flange DN200/PP

AD Flange 8" 150 lb RF

FE Flange DN200/SS

FF Flange DN250/PP

FG Flange DN250/SS

AE Flange 8" 150lb RF, ANSI/SS

AF Flange 10" 150lb RF, ANSI/SS

## Electronics

V 4...20mA/HART – 4-Wire/RS485/Modbus

## Cable Entry/Plug connection

M M20x1.5/without

N 1/2NPT/without

## Internal Display

A Yes

## External (remote) Display

A Yes

B No

3DLevelScanner S							
------------------	--	--	--	--	--	--	--

# PRODUCT INFORMATION

You can find at

**[www.apm-solutions.com](http://www.apm-solutions.com)**

downloads of the following:

- **Brochures**
- **Data Sheets**
- **Operating instructions manuals**
- **Software**
- **Certificates**
- **Product information**

and much, much more



## **APM Automation Solutions Ltd**

24 Habarzel Street

Tel Aviv 69710, Israel

Tel: +972 3 6488891

Fax : +972 3 6488892

info@apm-solutions.com

www.apm-solutions.com

Represented by



© 2006 A.P.M. Automation Solutions Ltd. All rights reserved. Information in this document is subject to change without notice. A.P.M. Automation Solutions Ltd. and the APM 3DLevelScanner are trademarks of A.P.M. Automation Solutions Ltd.