

3D LevelScanner S

DESCRIPTION OF INSTRUMENT FUNCTIONS

Level measurement in
solid applications

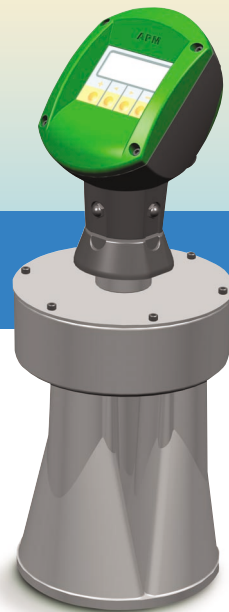

Table of Contents

1.	Basic Setup.....	1
1.1.	Function groups (00, 01, 03, ..., 0C, 0D)	1
1.2.	Functions (001, 002, 003, ..., 0D8, 0D9)	1
2.	Identifying the Functions	1
3.	Display	2
4.	Key Assignment.....	2
5.	Switching on the Instrument for the First Time.....	3
5.1	Basic/Default Displayed Screen	4
6.	Function Group Basic Setup (00)	5
6.1	Function measured value (000).....	5
6.2	Function media type (001).....	5
6.3	Function process cond. (00C)	5
6.4	Function Empty Calibr. (005).....	6
6.5	Function Full Calibr. (006)	6
6.6	Function Display (007)	7
7.	Function group Safety settings (01).....	8
7.1	Function output on alarm (010)	8
7.2	Function output on alarm (011)	10
7.3	Function output echo loss (012).....	10
7.4	Function delay time (014).....	11
7.5	Function safety dist. (015)	11
8.	Function Group Temperature (03)	13
8.1	Function measured temp. (030)	13
8.2	Function max. temp. limit (031)	13
8.3	Function max. meas. temp.(032).....	13
9.	Function Group Linearization (04)	14
9.1	Function level/ullage (040).....	14
9.2	Function customer unit (042).....	18
9.3	Function max. scale (046).....	18
10.	Function Group extended calibr (05).....	19
10.1	Function group extended calibr (05).....	19
10.2	Function selection (050)	19
10.3	Function pres. Map dist (054).....	19
10.4	Function cust. Tank map (055)	20
10.5	Function range of mapping. (052)	20
10.6	Function echo quality (056)	20
10.7	Function offset (057).....	21
10.8	Function output damping (058)	21
11.	Function Group output (06)	22
11.1	Function commun. Address (060).....	22
11.2	Function fixed cur. Value (064).....	22
11.3	Function curr. Output mode (063)	22
11.4	Function simulation (065).....	23
11.5	Function simulation value (066)	24
11.6	Function output current (067)	24

12.	Function Group Display (09)	25
12.1	Function language (092)	25
12.2	Function back to home (093)	25
12.3	Function no. of decimals (095)	25
12.4	Function display test (097)	26
13.	Function Group Diagnostics (0A)	27
13.1	Function built in test (0A8)	27
13.2	Function present error (0A1)	27
13.3	Function previous error (0A1)	27
13.4	Function clear last error (0A2)	28
13.5	Function reset (0A3)	28
13.6	Function unlock parameter 0A4	28
13.7	Function measured dist (0A5)	29
13.8	Function measured level (0A6)	29
14.	Function Group System Parameter (0C)	30
14.1	Function tag no. (0C0)	30
14.2	Function HW Interface (0C1)	30
14.3	Function Software Version (0C2)	30
14.4	Function Hardware Version (0C3)	31
14.5	Function serial no. (0C4)	31
14.6	Function distance unit (0C5)	31
14.7	Function temperature unit (0C6)	31

1. Basic Setup

The operating menu consists of two levels:

1.1. Function groups (00, 01, 03, ..., 0C, 0D)

The individual operating selection of the instrument functions are split up into different function groups. The function groups that are available include: *basic setup, safety settings, output, display, system parameters, diagnostics, extended calibration, linearization, temperature.*

1.2. Functions (001, 002, 003, ..., 0D8, 0D9)

Each function group consists of one or more functions. The functions perform the actual operation or parameter setting of the instrument. Numerical values can be entered here and parameters can be selected and saved. The available functions of the *basic setup (00)* function group include: *media type (002), process cond. (004), empty calibr. (005), etc.*

For example, if you wish to change the media type, do the following:

- Select the *basic setup (00)* function group.
- Select the *media type (002)* function (where the existing media type is selected).

2. Identifying the Functions

For simple orientation within the function menus, a three digit identifier is displayed on the right-hand side of the function on the display. The first two digits identify the function group. The third digit numbers the individual function within the function group.

Hereafter the position is always given in brackets (e.g. **media type (002)**) after the described function.

- basic setup 00
- safety settings 01
- temperature 03
- linearization 04
- extended calibration 05
- output 06
- display 09
- diagnostic 0A
- system parameters 0C

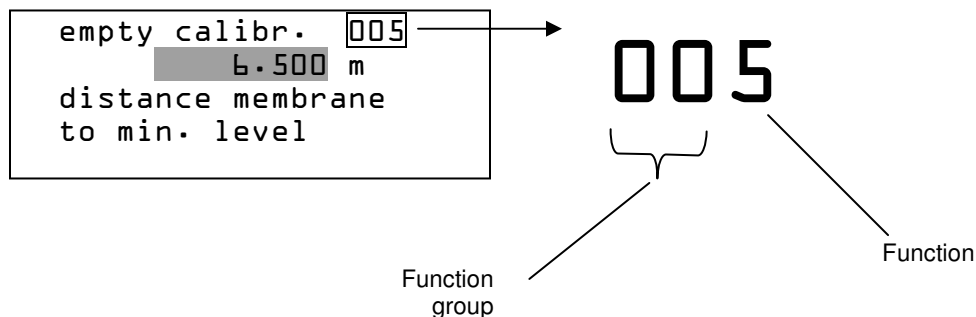

3. Display

The LCD display has four lines with 16-20 characters each. Display contrast adjustable through key combination. Example of the LCD display is shown below (a parameter is entered in the example).

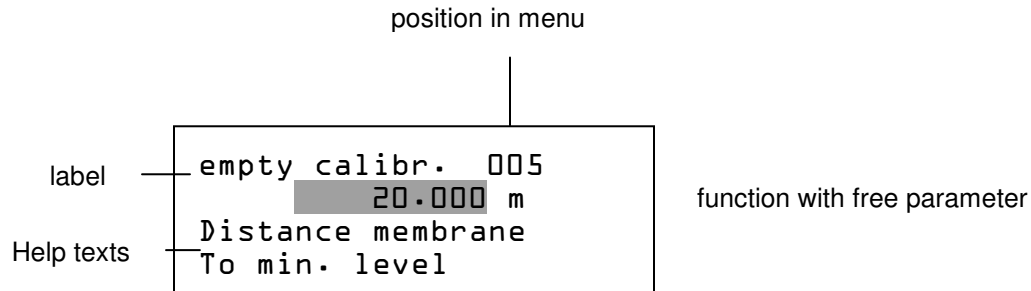

4. Key Assignment

The key assignment is attached in a separate file.

Note: the active selection is marked by an arrow (→) in front of the menu text.

5. Switching on the Instrument for the First Time

When the instrument is switched on for the first time, the following messages appear (an example).

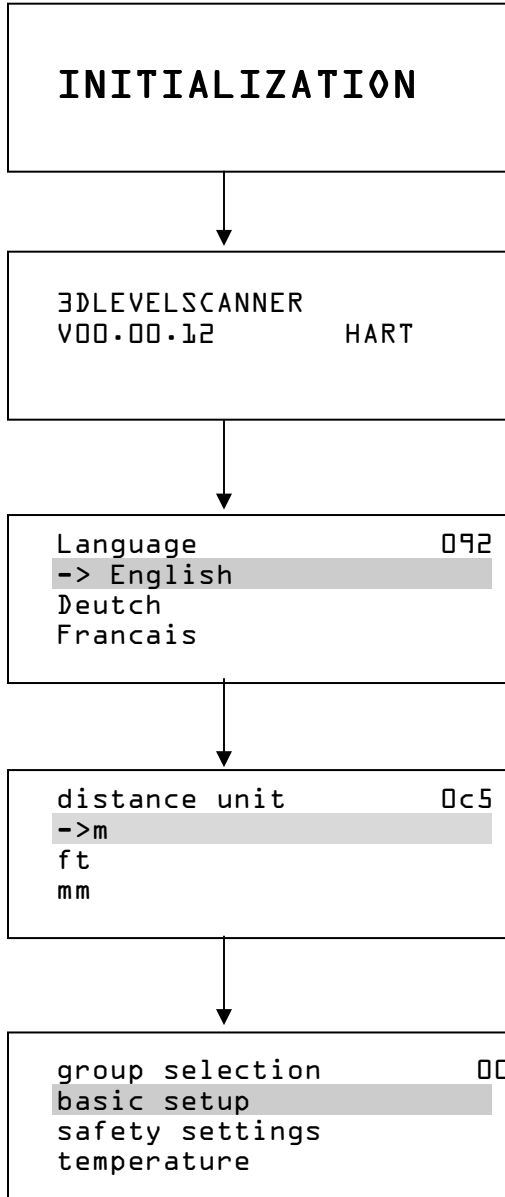

After five seconds, the following message appears:

```
Vxx.yy.zz Prot.
xx - hw version
yy - sw version
zz - sw version
prot - HART (Protocol name)
```

After five seconds or after you have pressed , the following message appears:

Select the language
(this message appears the first time the instrument is switched on)

Select the basic unit
(this message appears the first time the instrument is switched on)

After  is pressed, you reach the group selection. This selection enables you to perform the basic setup.

5.1 Basic/Default Displayed Screen

After startup the following screen is shown:

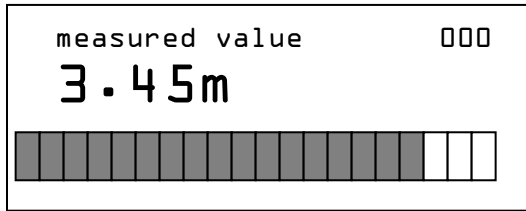

E – must be pressed to reach the group selection menu.

Esc. – button must be pressed for 3 seconds to return to the measured value basic screen

6. Function Group Basic Setup (00)

```
group selection      00
->basic setup
safety settings
linearization
```

6.1 Function measured value (000)

This function displays the current measured value in the selected unit (see customer unit (042) function). The number of digits after decimal point can be selected in the no. of decimals (095) function.

6.2 Function media type (001)

```
media type          001
->High Frequency
Solid
Solid SA
```

This function is used to select the media type:

- High Frequency
- Solid
- Solid SA

6.3 Function process cond. (00C)

```
process cond.       003
-> standard
Slow Change
Fast Change
```

- This function is used to select the process conditions, – choose the type of process for of the measured material. The options are: HF (for High Frequency use), solid or solid SA (for special application).

6.4 Function Empty Calibr. (005)

```
empty calibr.      005  
->6.500 m  
distance membrane  
to min. level
```

This function is used to enter the distance from flange (reference point of the measurement) to the point where 0% of material is defined.

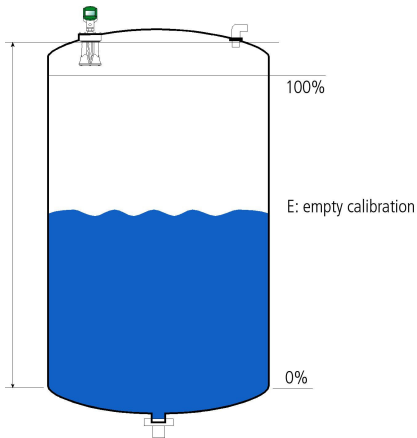

6.5 Function Full Calibr. (006)

```
full calibr.      006  
4.750 m  
span  
max: empty - BD
```

This function is used to enter the distance from the flange to the maximum level of material where the volume will be defined as 100% of material.

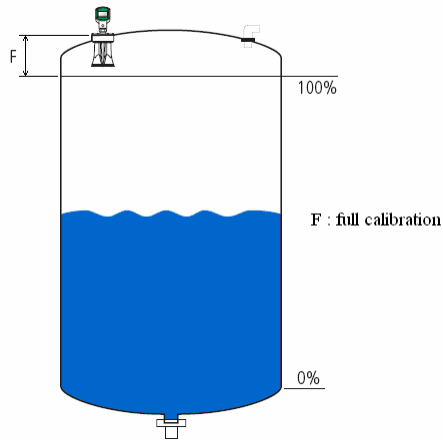

6.6 Function Display (007)

Dist./meas. value	007
dist.	2.463m
meas.v.	63.422%

The average distance measured from the reference point (flange) to the product surface and the level calculated with the aid of the empty adjustment are displayed. Check whether the values correspond to the actual level or the actual distance. The following cases can occur:

- Distance correct – level correct -> continue with the next function, check distance (051)
- Distance correct – level incorrect -> Check empty calibr. (005)
- Distance incorrect – level incorrect -> continue with the next function, check distance (051).

7. Function group Safety settings (01)

```
Group selection      01
->safety setting
Linearization
extended calibr.
```

7.1 Function output on alarm (010)

```
output on alarm     010
->MIN (<=3.6mA)
MAX (22mA)
hold
```

This function is used to select the reaction of the output on an alarm.

- MIN ($\leq 3.6\text{mA}$)
- MAX (22mA)
- hold
- user specific

MIN ($\leq 3.6\text{mA}$)

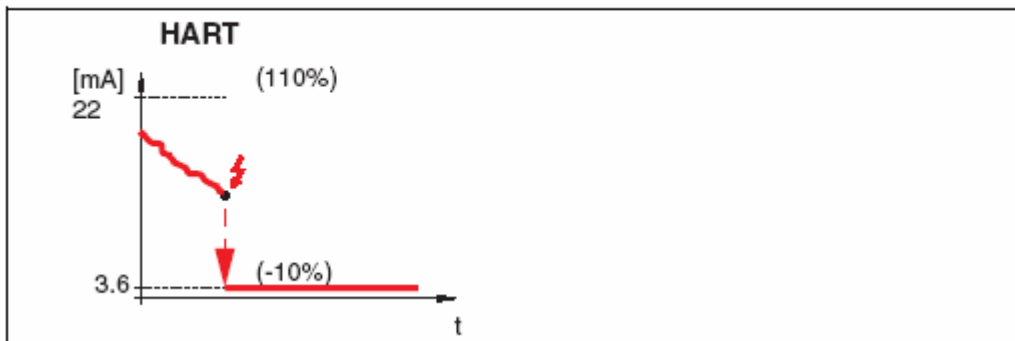

If the instrument is in alarm state, the output changes as follows:

- HART:MIN-Alarm 3.6mA

MAX (22mA)

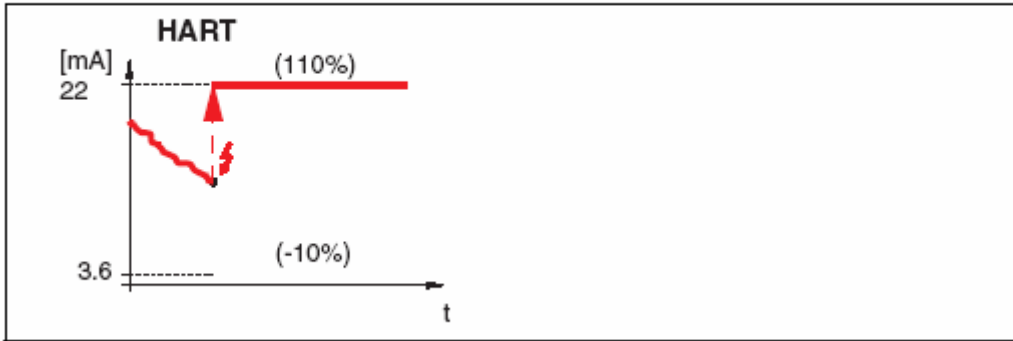

If the instrument is in alarm state, the output changes as follows:

- HART:MAX-Alarm 22 mA

hold

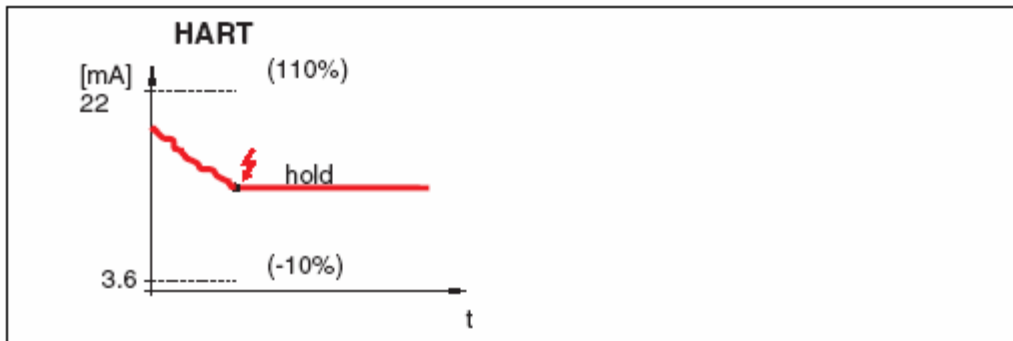

If the instrument is in alarm state, the last measured value is held.

user specific

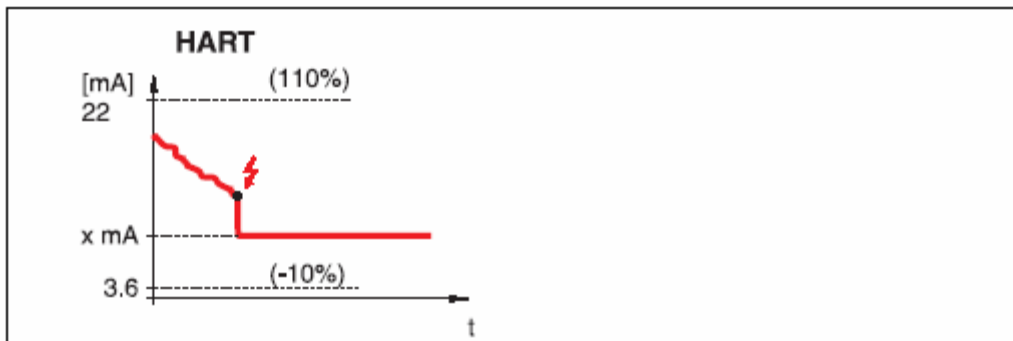

If the instrument is in alarm state, the output is set to the value configured in "output on alarm" (O11) (x mA)

7.2 Function output on alarm (011)

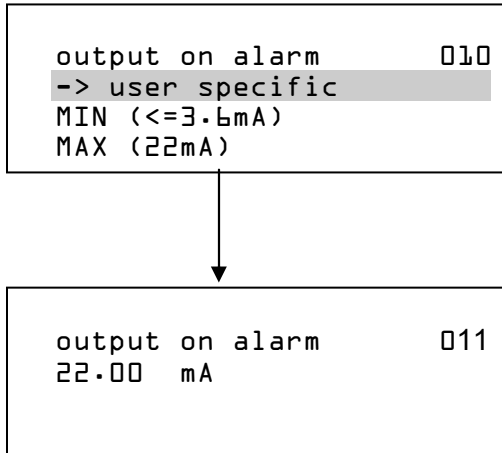

Upon alarm, the output current is set to the entered value in mA. This function is active when you selected user specific in the output on alarm (010) function.

7.3 Function output echo loss (012)

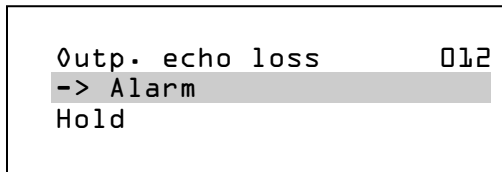

Use this function to set the output response on echo loss.

- Alarm
- Hold

alarm

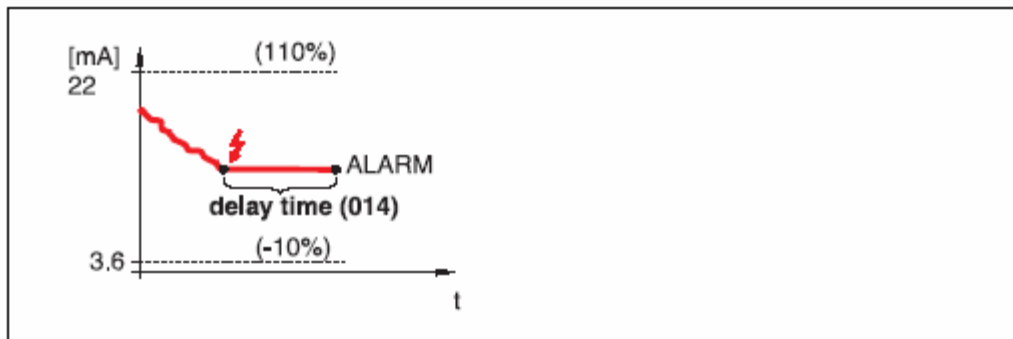

On echo loss, the instrument switches to alarm state after an adjustable delay time (014). The output response depends on the configuration set in output on alarm (010).

hold

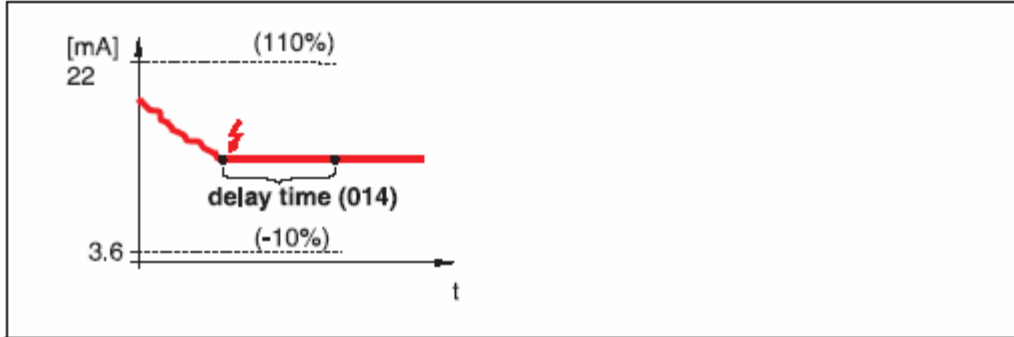

On echo loss, a warning is generated after a definable "delay time" (014). Output is held.

7.4 Function delay time (014)

```

delay time          014
30 s
in case of echo loss
max. 4000 sec.

```

Use this function to enter the delay time (Default = 30 s) after which a warning is generated on echo loss, or after which the instrument switches to alarm state.

7.5 Function safety dist. (015)

```

safety distance     015
0.100 m
From antenna tip/
Lower edge of horn

```

A configurable safety distance is placed before the blocking dist. (059). This distance warns you that any further level increase would make the measurement invalid, for example, when touching the antenna area.

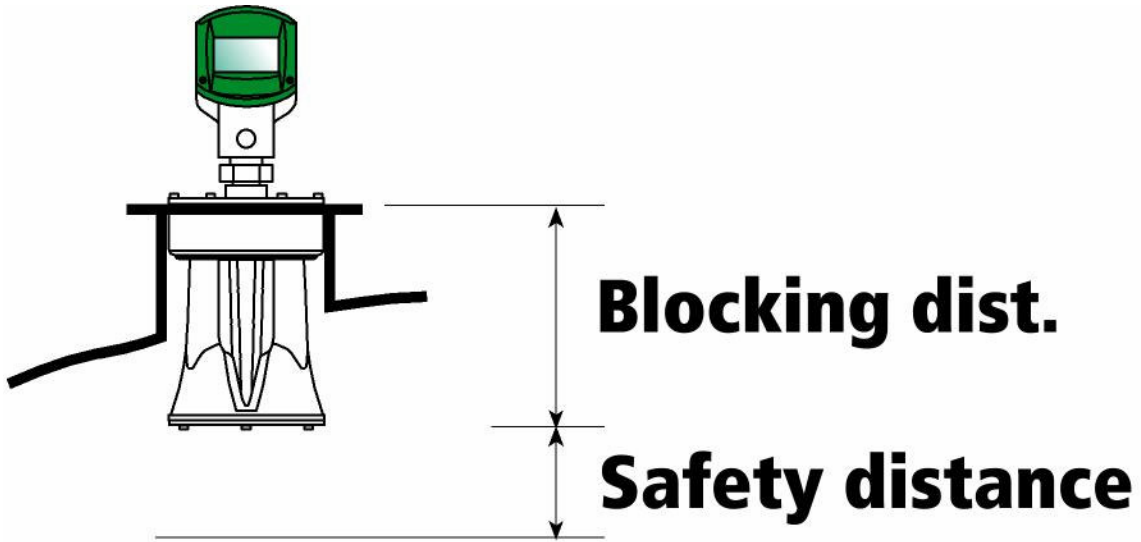

Enter the size of the safety distance here. The default value is 0.1 m.

8. Function Group Temperature (03)

```
Group selection      03->  
-> temperature  
linearization  
extended calibr.
```

8.1 Function measured temp. (030)

```
measured type      030  
72.9 F
```

In this function, the temperature recorded by the sensor is displayed. The temperature unit is determined by the function temperature unit (0C6).

8.2 Function max. temp. limit (031)

```
max. temp. limit   031  
176.0 F
```

In this function, the maximum permitted temperature of the sensor is displayed. The temperature unit is determined by the function temperature unit (0C6). If this temperature is exceeded, the sensor may become damaged.

8.3 Function max. meas. temp.(032)

```
max. measured temp 032  
76.2 F
```

In this function, the maximum temperature ever recorded by the sensor is displayed. The temperature unit is determined by the function temperature unit (0C6). This function is not influenced by a reset of the parameters.

9. Function Group Linearization (04)

```
Group selection      04->
-> linearization
Extended calibr.
output
```

9.1 Function level/ullage (040)

```
level/ullage        040
-> level CU
Level DU
ullage CU
```

- level CU
- level DU
- ullage CU
- ullage DU

level CU

Level in customer units. The measured value can be linearized. The linearization (041) default value is set to a linear 0...100%.

level DU

Level in the selected distance unit (0C5).

ullage CU

Ullage in customer units. The value can be linearized. The linearization (041) default value is set to a linear 0...100%.

ullage DU

Ullage in the selected distance unit (0C5).

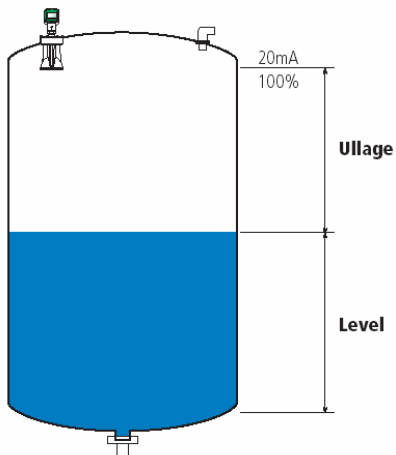

DU – distance unit

When DU is selected either in ullage or level, the vessel is linear e.g. a cylindrical vertical vessel. You can measure in customer units by entering a maximum volume in liters or percent/mass in tons/m³.

You can select the customer unit (042). Define the volume value corresponding to the calibration in max. scale (046). This value corresponds to an output of 100% (= 20 mA for HART).

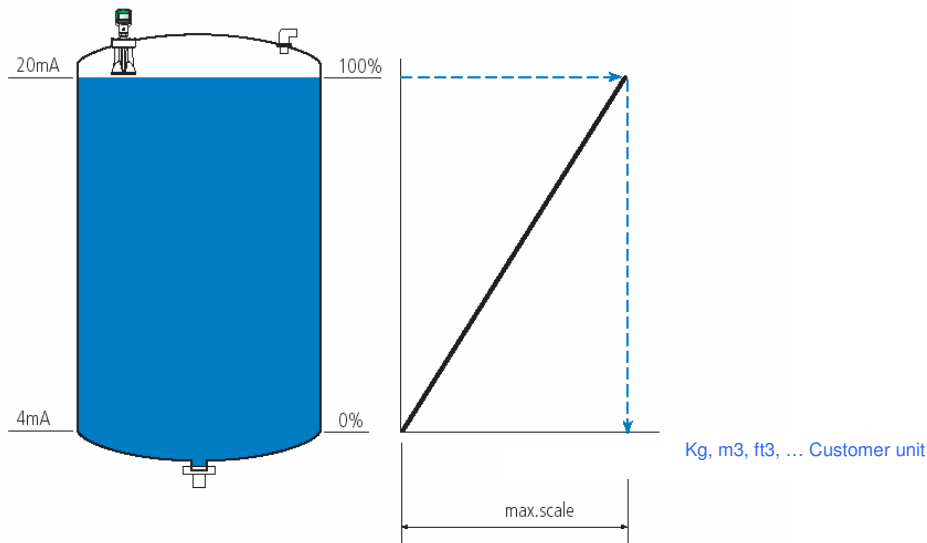
**manual**

If the level is not in proportion to the volume or weight within the set measuring range, you can enter a linearization table in order to measure in customer units. The requirements are as follows:

- The 32 (max.) value pairs for the linearization curve points are known.
- The level values must be given in ascending order. The curve is monotonously increasing.
- The level heights for the first and last points on the linearization curve correspond to empty and full calibration respectively.

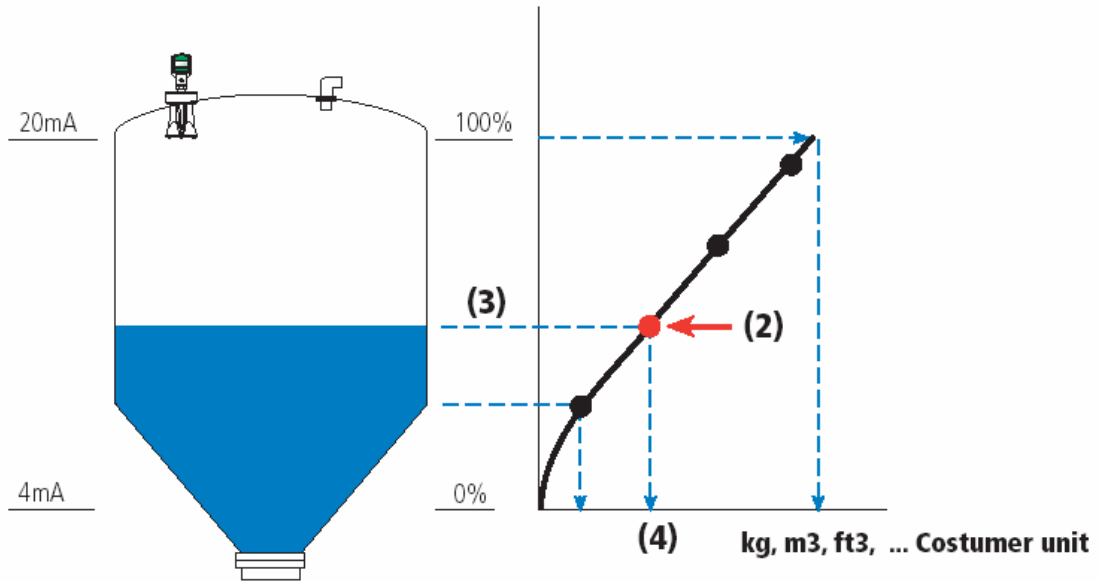

Each point (2) in the table is described by a value pair: level (3) and, for example, volume (4). The last value pair defines the 100% output (= 20 mA for HART).

```
linearisation      041  
-> manual  
semi-automatic  
table on
```



```
linearisation      043  
Tab.no. 1  
Level 0.000m  
Volume 0.000%
```

select the table point (Point1)



```
linearisation      044  
Tab.no. 1  
Level 0.000m  
Volume 0.000%
```

select the level of Point 1



```
linearisation      045  
Tab.no. 1  
Level 0.000m  
Volume 0.000%
```

Enter the corresponding volume



```
next point        045  
-> yes  
no
```

Enter a further table point?



```
linearisation      043  
Tab.no. 2  
Level 0.000m  
Volume 0.000%
```

Next table point

Note!

After making entries into the table, activate it with table on. The 100% value (=20 mA for HART) is defined by the last point in the table.

table on

An entered linearization table only becomes effective when activated.

clear table

Before making entries into the linearization table, any existing tables must be deleted. The linearization mode automatically switches to linear.

9.2 Function customer unit (042)

```
customer unit      042
-> %
l
m³
tons
```

You can select the customer unit with this function.

Volume: percent (%), liters or m³

Weight: tons

9.3 Function max. scale (046)

```
max. scale        046
100.000 &
```

You can enter the end value of the measuring range with this function. This input is necessary if you selected linear in the linearization (041) function.

10. Function Group extended calibr (05)

10.1 Function group extended calibr (05)

```
Group selection      05->  
-> extended calibr.  
output  
display
```

10.2 Function selection (050)

```
selection            050  
-> common  
mapping  
extended map.
```

Select the function of the extended calibration.

- common
- extended map.

10.3 Function pres. Map dist (054)

```
pres. Map dist      054  
0.000 m
```

Displays the distance up to which a mapping has been recorded. A value of 0 indicates that no mapping was recorded so far.

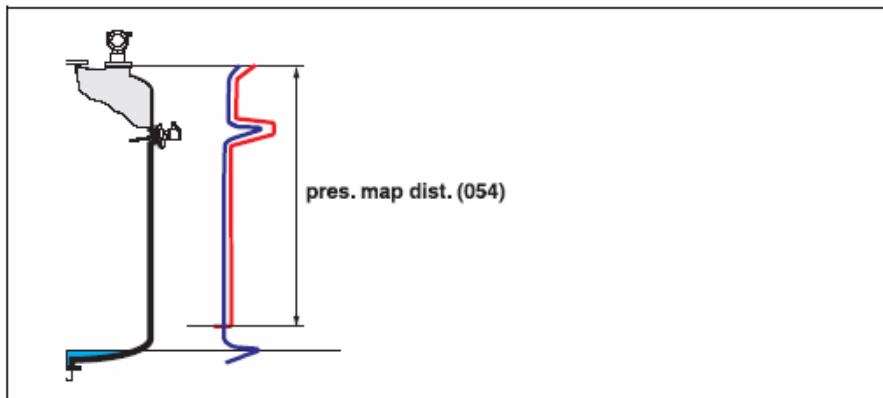

10.4 Function cust. Tank map (055)

```
Cust. Tank map      055
-> Reset mapping
New mapping
Update mapping
```

High sockets or vessel installations, such as struts or agitators as well as buildup and weld joints on the vessel walls, cause interfering reflections which can impair the measurement. False echo storage detects and marks these false echoes, so that they are no longer taken into account in level measurement. A false echo memory should be created with an empty vessel so that all potential interfering reflections will be detected.

- **Reset mapping** – deletes the complete false echo mapping.
- **New mapping** – maps the entire false echoes between the flange of the device to the surface of material or the bottom of the silo.
- **Update mapping** - When updating the range of mapping in case of decrease in material's level, Update Mapping will keep the last false echo mapping in memory, and add and update the false echoes (from the flange to the updated distance).

10.5 Function range of mapping. (052)

```
Range of mapping.  052
-> 10.200 m
Enter value input of
Mapping range
```

After choosing New/Update mapping, set the distance in which the device will make the false echo mapping up to this range.

CAUTION!

The range of mapping distance must end 0.5 m before the echo of the actual level. For an empty vessel, do not enter *distance to bottom of vessel*, but *distance to bottom of vessel – 0.5 m*. If a mapping already exists, new mapping is overwritten up to the distance specified in the range of mapping (052). Use Update mapping when the level has decreased and an update of false echoes is needed. Beyond this value the existing mapping remains unchanged.

10.6 Function echo quality (056)

```
echo quality      056
52.8 dB
```

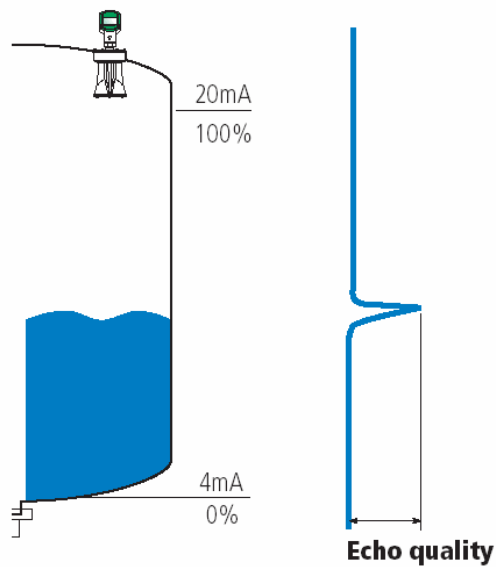

The echo quality is the benchmark for measurement reliability. It describes the amount of reflected energy and depends primarily on the following conditions:

- Surface characteristics (waves, foam etc.)
- Distance between sensor and product.

10.7 Function offset (057)

```

offset                057
-> 0.000 m
Will be added to the
measure level

```

This function corrects the measured distance/level by a constant value. The entered value is added to the measured distance.

10.8 Function output damping (058)

```

output damping       058
030 s

```

Output damping time is the time the samplings are being averaged. This parameter also influences the time an output requires to react to a sudden level jump. The higher the value is, the more average time there is and the output will be more stable.

11. Function Group output (06)

```
Group selection      06->  
-> output  
display  
diagnostics
```

11.1 Function commun. Address (060)

```
commun. address     060  
↓
```

Enter the communication address for the instrument with this function.

- Standard: 0
- Multidrop: 1-63

In multidrop mode, the default value of the output current is 4 mA. It can be modified in the function fixed cur. value (064).

11.2 Function fixed cur. Value (064)

```
fixed cur. Value    064  
-> 4.00 mA
```

Set the fixed current value with this function. This entry is necessary when you have switched on the fixed current (063) function. User input: 3,8...20,5 mA

11.3 Function curr. Output mode (063)

```
curr. Output mode   063  
-> standard (4-20mA)  
Inverted (20-4mA)  
Fixed
```

standard

The total measuring range (0 ... 100%) will be mapped to the current interval (4 ... 20 mA) respectively.

Inverted (20-4mA)

The total measuring range (0 ... 100%) will be mapped to the current interval (20 ... 4 mA) respectively.

fixed current

The current is fixed. The actual measured value is transmitted by the HART signal only. The value of the current is defined in the fixed current (064) function.

11.4 Function simulation (065)

```
simulation           065
-> sim. off
sim. level
sim. volume
```

If necessary, the linearization, output signal and current output can be tested with the simulation function. You have the following simulation options:

- sim. off (default value)
- sim. level
- sim. volume
- sim. current

sim. off

Simulation is switched off.

sim. level

Enter the level value in **simulation value (066)**.

The functions

- measured value (000)
- measured level (0A6)
- output current (067)

follow the entered values.

sim. volume

Enter the volume value in **simulation value (066)**.

The functions

- measured value (000)
- output current (067)

follow the entered values.

sim. current (HART only)

Enter the current value in **simulation value (066)**.

The output current (067) function follows the entered values.

11.5 Function simulation value (066)

After selecting the sim. level option in the simulation (065) function, the following message appears in the display:

```
simulation value      066  
-> 2.54 m
```

The level can be entered.

After selecting the **sim. volume** option in the **simulation (065)** function, the following message appears in the display:

```
simulation value      066  
-> 23.16 %
```

The volume can be entered.

After selecting the **sim. current** option in the **simulation (065)** function, the following message appears in the display:

```
simulation value      066  
8.00 mA
```

(only for Hart instruments) Enter the output current.

11.6 Function output current (067)

```
output current       067  
4.00 mA
```

Displays the output current in mA.

12. Function Group Display (09)

```
Group selection      09
-> display
diagnostics
system parameters
```

12.1 Function language (092)

```
language            092
-> English
Deutsch
Français
```

Selects the display language to one of the following.

- English
- Deutsch
- Français
- Español
- Italiano

12.2 Function back to home (093)

```
back to home       093
-> 300 s
```

If no entry is made using the display during the specified time period, the display returns to the measured value display. 9999 s means that there is no return. User input: 3...9999 s.

12.3 Function no. of decimals (095)

```
no. of decimals    095
-> x.xx
x.xxx
x
```

- x
- x.x
- x.xx (default value)
- x.xxx

12.4 Function display test (097)

```
display test      097  
-> off  
on
```

This function tests the pixels of the LCD by turning them all on. To abort the test, use any key to turn off all the pixels and to go back to normal screen view.

13. Function Group Diagnostics (0A)

```
Group selection      0A
-> diagnostics
system parameters
```

13.1 Function built in test (0A8)

```
Built-In Test      0A8
-> Perform no BIT
Transducers BIT
```

Performing Built-In-Test to the transducers.

If Perform no BIT is chosen, the next screen will be present error (0A0) screen which is the next screen. If Transducers BIT is chosen then the transducers will be checked and will give a result within few seconds.

13.2 Function present error (0A1)

```
present error      0A1
Simulation ch. 1 on
```

The present error is shown with this function.

13.3 Function previous error (0A1)

```
previous error     0A1
Simulation ch. 1 on
```

The last error that has occurred is shown with this function.

13.4 Function clear last error (0A2)

```
clear last error      0A2
-> keep
erase
```

- keep – keeps the last error
- erase – erases the last error

13.5 Function reset (0A3)

```
reset                0A3
-> continue
reset
reset to factory settings
```

Continue – perform no reset and go to the next screen.

Reset – resets the device. This function is logically similar to turning the device off and then on again.

Reset to Factory Settings – resets the device and sets the instrument back to the factory settings. This can lead to an impairment of the measurement.

A reset is only necessary:

- if the instrument no longer functions
- if the instrument must be moved from one measuring point to another
- if the instrument is being de-installed /put into storage/installed

A reset to factory settings is necessary when it's necessary to configure all the parameters all over again.

The reset to factory settings code is 123. In case the user presses the 'E' button by mistake when it's on reset to factory settings.

13.6 Function unlock parameter 0A4

```
unlock parameter    0A4
100
```

Set-up can be locked and unlocked with this function. By entering the unlock parameter (on the display or via communication) 100 = for HART devices the instrument is released for operation.

13.7 Function measured dist (0A5)

measured dist.	0A5
2.463 m	

Display of measured distance in the selected distance unit (0C5).

13.8 Function measured level (0A6)

measured level	0A6
2.541 m	

Display of measured level in the selected **distance unit (0C5)**.

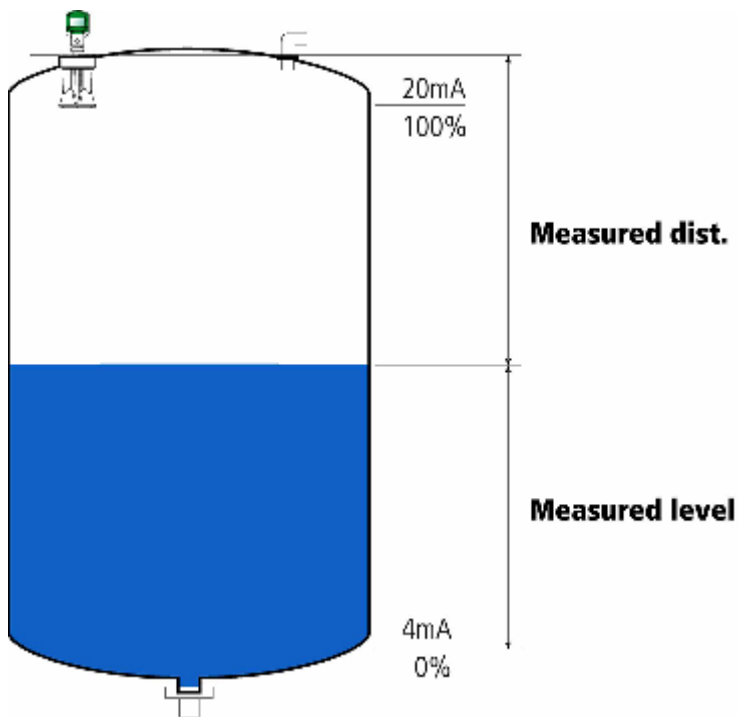

14. Function Group System Parameter (0C)

```
Group selection    0C->  
-> system parameters
```

14.1 Function tag no. (0C0)

```
tag no.          0C0  
-----
```

You can define the tag name with this function, by selecting the following option:

- 16 alphanumeric characters for HART instruments (8 using the HART universal command)

14.2 Function HW Interface (0C1)

```
HW Interface      0C1  
HART  
4-20mA  
RS485
```

Displays the HW interfaces supports by the electronic card.

14.3 Function Software Version (0C2)

```
Software Version  0C2  
0208000
```

This function displays the software version in the following format:

First two digits (e.g. 02) is the major version. Second two digits (e.g. 08) is the minor version and the last 3 digits (e.g. 000) are the patch number.

14.4 Function Hardware Version (0C3)

```
Hardware Version  0C3
005
```

This function displays the hardware version of the electronic card.

14.5 Function serial no. (0C4)

```
Serial no.       0C4
024690001
```

This function displays the electronic card's serial number.

14.6 Function distance unit (0C5)

```
distance unit    0C5
-> m
cm
mm
```

You can select the basic distance unit with this function to one of the following.

- m (default value)
- cm
- mm

14.7 Function temperature unit (0C6)

```
temperature unit 0C6
-> F
C
```

In this function you select the temperature unit to one of the following.

Selection:

- °C
- °F

DESCRIPTION OF INSTRUMENT FUNCTIONS

You can find at

www.apm-solutions.com

downloads of the following:

- **Brochures**
- **Data Sheets**
- **Operating instructions manuals**
- **Software**
- **Certificates**
- **Product information**

and much, much more



APM Automation Solutions Ltd

24 Habarzel Street
Tel Aviv 69710, Israel
Tel: +972 3 6488891
Fax : +972 3 6488892
info@apm-solutions.com
www.apm-solutions.com

Represented by

