

3D LevelScanner



OPERATING INSTRUCTIONS

Level / Volume
measurement in
solid applications



Table of contents

1	ABOUT THIS DOCUMENT	4
1.1	SYMBOLISM USED.....	4
1.2	FOR YOUR SAFETY	4
1.2.1	<i>Authorized personnel</i>	4
1.2.2	<i>Appropriate use</i>	4
1.2.3	<i>Warning about misuse</i>	4
1.2.4	<i>General safety instructions</i>	4
1.2.5	<i>CE conformity</i>	5
1.2.6	<i>Safety information for Ex areas</i>	5
1.2.7	<i>Environmental instructions</i>	5
2	PRODUCT DESCRIPTION	6
2.1	DELIVERY CONTENTS	6
2.2	COMPONENTS	6
2.3	THEORY OF OPERATION.....	6
2.4	WIDE APPLICATION RANGE.....	6
2.5	ADVANTAGES	7
2.6	STORAGE AND TRANSPORT	7
2.6.1	<i>Storage and transport temperature</i>	7
3	MOUNTING	8
3.1	INSTALLATION POSITION	8
3.2	MOISTURE	8
3.3	MEASURING RANGE	8
3.4	PRESSURE.....	8
3.5	INSTALLATION LOCATION	9
3.6	MOUNTING DIRECTION.....	10
3.7	SOCKET	11
3.8	SENSOR ORIENTATION.....	12
3.9	INFLOWING MATERIAL	12
4	CONNECTIONS	13
4.1	GENERAL REQUIREMENTS	13
4.2	POWER SUPPLY	13
4.2.1	<i>Connection Cable</i>	13
4.3	CONNECTION PROCEDURE	13
4.4	WIRING PLANS	14
5	ADJUSTMENT	15
5.1	3DLEVELSCANNER S - LCD PANEL	15
5.2	ADJUSTING THE SCANNER USING THE SOFTWARE TOOL	17
6	OPERATION.....	18
6.1	OPERATING MENU.....	18
6.2	FUNCTION INDICATION	18
6.3	SWITCHING ON	19
6.4	BASIC/DEFAULT SCREEN.....	20
6.5	SETUP PROCEDURE	20
6.5.1	<i>Address setting for several sensors on one input – RS485-Multidrop (Daisy Chain)</i>	20
6.5.2	<i>Parameter adjustment</i>	20
6.5.3	<i>Medium selection</i>	21
6.5.4	<i>Process Conditions</i>	21
6.5.5	<i>Performing empty calibration adjustment</i>	21

6.5.6	<i>Performing Full Calibration adjustment</i>	23
7	FALSE ECHO STORAGE	24
7.1	RANGE OF MAPPING FUNCTION (052)	24
8	OPTIONAL SETTINGS	24
8.1	BASIC/DEFAULT DISPLAYED SCREEN	25
8.2	LINEARIZATION SCREEN	25
8.3	EXTENDED CALIBRATION SCREEN	26
8.4	OUTPUT SCREEN	26
8.5	DISPLAY SCREEN	27
8.6	MEASURED PARAMETERS.....	28
8.7	DEVICE INFO	29
8.8	DEVICE RESET.....	29
9	MAINTENANCE AND FAULT RECTIFICATION	30
9.1	MAINTENANCE	30
9.2	FAULT RECTIFICATION	30
9.2.1	<i>24 hours support</i>	30
9.2.2	<i>Checking the 4 ... 20 mA signal</i>	30
9.3	REPLACING THE ELECTRONICS	31
9.4	DEVICE REPAIR.....	31
10	DISMOUNTING	32
10.1	DISMOUNTING PROCEDURE	32
11	DIMENSIONS	33
12	APPENDIX	35
12.1	TECHNICAL DATA	35
12.2	AMBIENT CONDITIONS	36
12.3	PROCESS CONDITIONS.....	36
12.4	PROCESS TEMPERATURE.....	36
12.5	ELECTROMECHANICAL DATA.....	36

Table of Figures

<i>Figure 1: Measuring range</i>	8
<i>Figure 2: Mounting on arched vessel tops</i>	9
<i>Figure 3: Mounting Direction</i>	10
<i>Figure 4: Recommended socket mounting</i>	11
<i>Figure 5: Inflowing material</i>	12
<i>Figure 6: Connection Scheme</i>	14
<i>Figure 7: 3DLevelScanner S front panel LCD</i>	15
<i>Figure 8: Software Tool connection</i>	17
<i>Figure 9: Empty and Full Calibration</i>	22
<i>Figure 11: 3DLevelScanner S with horn antenna in threaded version</i>	33
<i>Figure 12: 3DLevelScanner S with horn antenna in flange version</i>	33
<i>Figure 13: 3DLevelScanner S housing</i>	34
<i>Figure 14: Voltage diagram</i>	35
<i>Figure 15: Accuracy</i>	37

1 About this document

This operation manual provides complete instructions for quick setup and safe operation of the 3DLevelScanner S. This manual is designed for trained personnel. Please read it carefully before you proceed.

1.1 Symbolism used

Information, tip, note



Additional information

Indication of helpful Additional information



Caution, warning, risk of danger

Indication of a potentially dangerous situation, which could result in serious injury to persons and/or damage to the 3DLevelScanner.



Ex applications

Indication of special instructions for Ex applications.



Earth (ground) terminal

Indication of functional earth to use for grounding the 3DLevelScanner S.

1.2 For your safety

1.2.1 Authorized personnel

All operations described in this manual must be carried out by authorized trained personnel only. For safety and warranty reasons, any internal work on the devices must be carried out by manufacturer-authorized personnel only.

1.2.2 Appropriate use

The 3DLevelScanner S is a sensor designed for continuous level / volume measurement.

1.2.3 Warning about misuse

Inappropriate or incorrect use of the device can give rise to application-specific hazards, e.g., vessel overfill or damage to system components through incorrect mounting or adjustment.

If the 3DLevelScanner is used in a manner not specified in this manual, the protection provided by the 3DLevelScanner will be impaired.

1.2.4 General safety instructions

The 3DLevelScanner is a high-tech device requiring strict observance of standard regulations and guidelines. The user must take note of the safety instructions in this operating manual, as well as local and national electrical codes should be always

considered during installation and all common safety regulations and accident prevention rules.

1.2.5 CE conformity

The 3DLevelScanner conforms to CE's EMC and NSR standards. CE conformity is as follows:

EMC (2004/108/EC)

- Emission EN 61326: 1997 (class B)
- Susceptibility IEC / EN 61326:1997 + A1: 1998 + A2:2001 + A3:2003

NSR (73/23/EWG) EN 61010-1: 2001

1.2.6 Safety information for Ex areas



Please note the Ex-specific safety information for installation and operation in Ex areas. These safety instructions are part of the operating instructions manual that comes with Ex-approved devices.



WARNING – Substitution of components may impair Intrinsic Safety.

WARNING – To prevent ignition of flammable or combustible atmospheres, read, understand and adhere to the manufacturer's live maintenance procedures.

1.2.7 Environmental instructions

Protection of the environment is one of our most important duties. Please help us fulfill this obligation by observing the environmental instructions in the following chapters of this manual:

- Storage and transport, page 7.
- Dismounting, page 32.

2 Product description

2.1 Delivery contents

- 3DLevelScanner S sensor
- Documentation
- CD with the 3DLevel Manager software and marketing materials
- Ex-specific safety instructions (with Ex versions)
- Certificates if applicable

2.2 Components

- Special horn antenna
- Process fitting (depending on the flange or thread version)
- Housing with electronics, optionally available with a plug connector and connection cable

The components are available in different configurations.

2.3 Theory of Operation

The APM 3DLevelScanner™ is the only device presently available that delivers accurate measurement of bulk solids and powders – regardless of the type of material or product characteristics, type and size of storage silo, bin or container, and harshness of the storage environment. It incorporates APM's unique dust-penetrating technology to achieve an unrivalled degree of process measurement and inventory control.

The 3DLevelScanner employs an array of three antennas to transmit low frequency pulses and to receive echoes of the pulses from the contents of the silo, bin, or other container. Using these antennas, the unit measures not only the time/distance of each echo, but also its direction. The device's Digital Signal Processor samples and analyzes the received signals to provide accurate measurements of the level, volume, and mass of the stored contents and generates a 3D representation of the actual allocation of the product within the container for display on remote computer screens. This unique device measures practically any kind of material stored in a great variety of containers, including silos, large open bins, bulk solid storage rooms, stockpiles, and warehouses. It maps build-up loads and other irregularities that randomly form over time, offering solutions for this and many other previously inaccessible challenging applications.

2.4 Wide Application Range

The 3DLevelScanner S measures practically any kind of solid material, stored in practically unlimited variety of containers, including large open bins, bulk solid storage rooms and warehouses, mapping loads that randomly form over time inside silos, and many other challenging applications that were not possible until now. The sensor can measure ranges of up to 70 m (230 ft) and generate 3D maps of the surface.

2.5 Advantages

- **Practice-oriented device versions** - The 3DLevelScanner S is available with both thread and flange fittings.
- **Service and maintenance-friendly** - Thanks to the non-contact measuring principles, the 3DLevelScanner S is particularly easy to service and maintain.
- The only volume measurement device for solid applications
- Suitable for measuring all solid materials (including ones with low dielectric constants)
- Operates in dusty and moisture environment
- Profiles and warns of adhesions of materials to the walls of vessels
- The only device that measures volume as well as minimum level and maximum level
- Self cleaning antenna
- 3D mapping visualization tool to help decide where to fill from (in vessels with multiple filling points)
- Most reliable sensor on the market (has 3 transmitters and 3 receivers)

2.6 Storage and transport

The device is protected by special packaging during transport, and is guaranteed to handle normal loads during transport.

2.6.1 Storage and transport temperature

- For storage and transport temperature please see *Technical data, Ambient conditions, page 36*.

3 Mounting

3.1 Installation position

Install the 3DLevelScanner S where you can easily reach it for mounting and connecting. You can install the housing in eight different positions. In each position, the housing can be rotated 45°.

3.2 Moisture

Use the recommended cable (see *Connections, page 13.*) and tighten the cable connection.

For additional protection against moisture, lead the connection cable downward in front of the cable entry. Rain and condensation water can thus drain off. This applies mainly to mounting outdoors, in areas where moisture is expected (e.g., by cleaning processes), or on cooled or heated vessels.

3.3 Measuring Range

The reference plane of the sensor measuring range is the seal surface of the thread or the lower side of the flange. All information regarding the measuring range as well as the internal signal processing relates to the reference plane.

NOTE:

If the container content reaches the antenna, buildup could form on it over time and cause measurement errors.

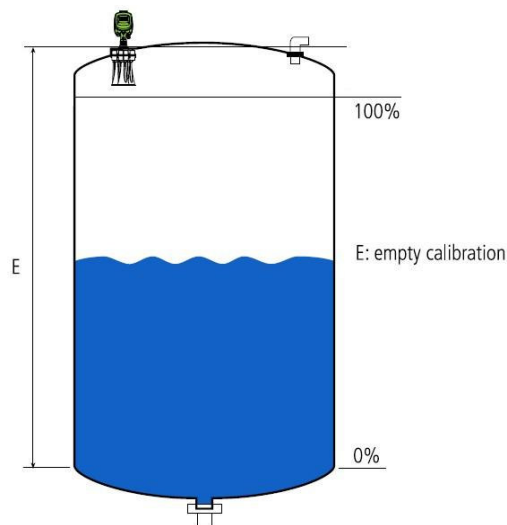

Figure 1: Measuring range

3.4 Pressure

The process fitting must be sealed if there is low pressure in the vessel. Before use, verify that the seal material is resistant to the medium. The maximum permissible pressure is stated in *Technical data, page 35*, and on the type label of the sensor.

3.5 Installation Location

When mounting the 3DLevelScanner S, a distance of at least 400 mm from the vessel wall (500mm from the center of the scanner to the vessel wall) should be maintained. If the 3DLevelScanner S is installed in the center of the vessel, multiple echoes can occur.

Note: It's recommended **not** to install the 3DLevelScanner S in the center of the silo.

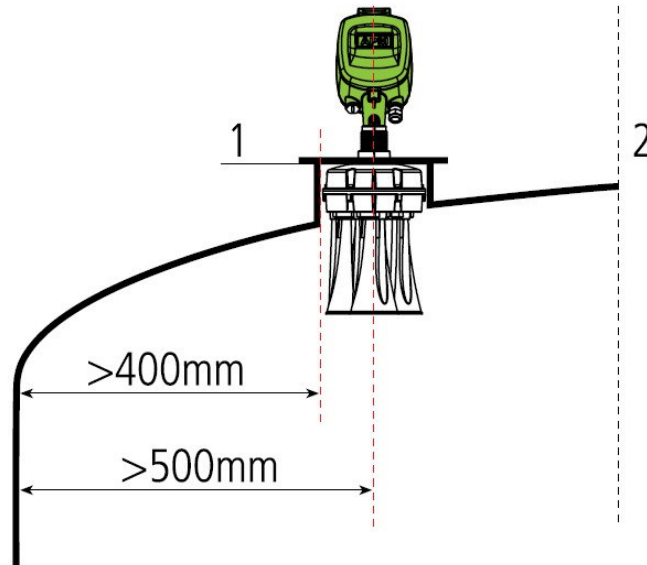

Figure 2: Mounting on arched vessel tops

1. Reference plane
2. Vessel center or symmetry axis

If this distance cannot be maintained, a false echo storage should be carried out. For more information see *False echo storage*, page 24. This applies particularly if buildup of residue on the vessel wall is expected.

Note: It is very important to use "range of mapping" right after installation, in order to map all false echoes. The results are better when the silo is empty.

3.6 Mounting Direction

The 3DLevelScanner must be mounted in the right direction in order to scale and adjust the position of the unit.

The mounting direction is indicated by a sticker labeled 0^0 on the instrument (see image below). The 0^0 must point to the center of the vessel (including square vessels and open bins).

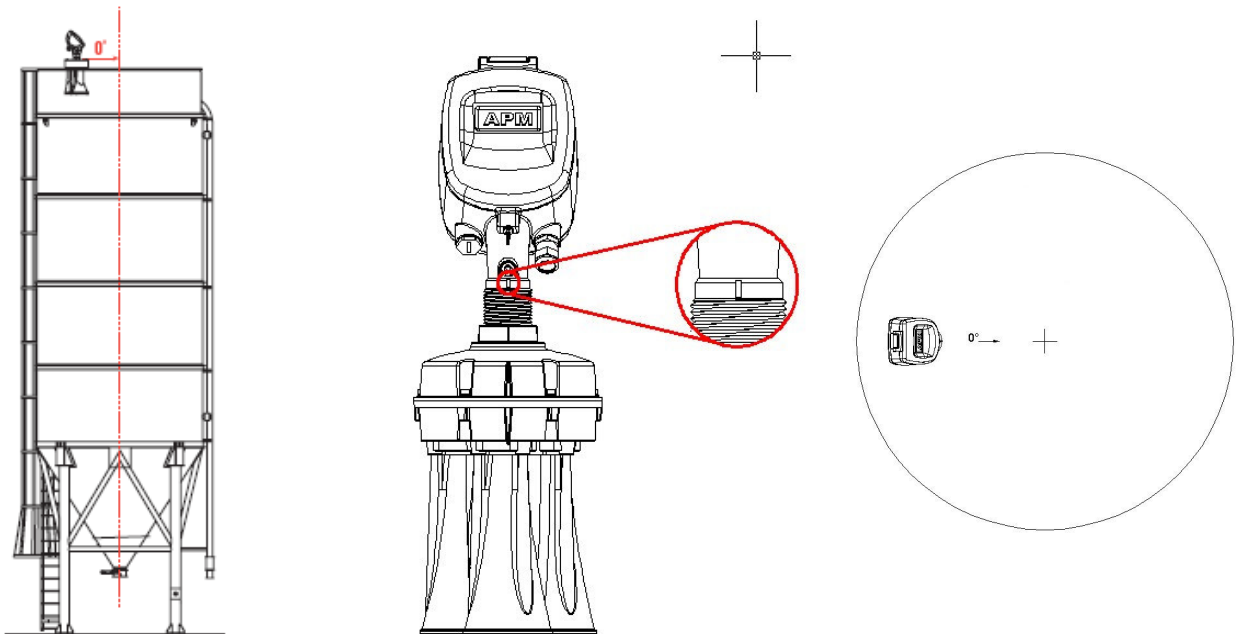

Figure 3: Mounting Direction

3.7 Socket

Socket pieces should be positioned so that the antenna end protrudes at least 10 mm (0.4 inch) out of the socket.

Important Note: Rails/frames should never interfere with the beam angle transmitted and received (see figures below).

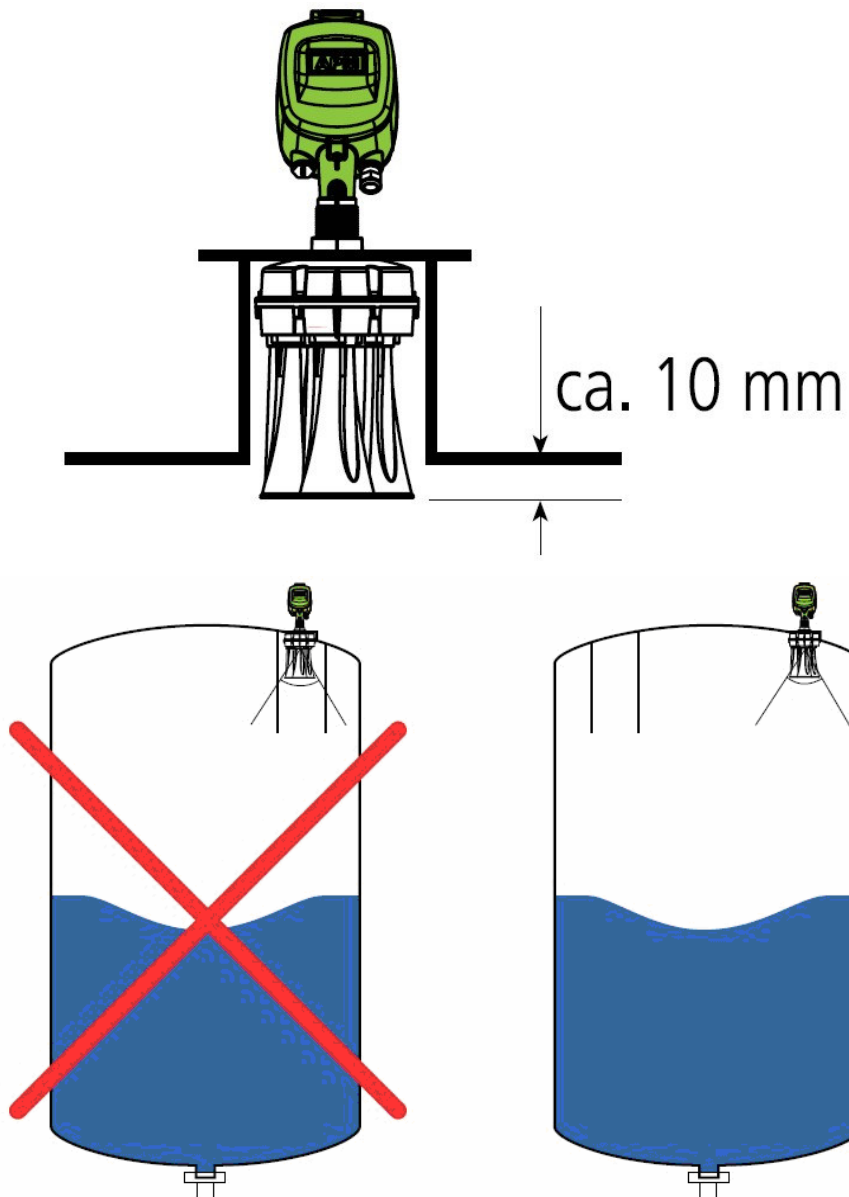

Figure 4: Recommended socket mounting

3.8 Sensor Orientation

The sensor will generate optimal performance if it is located halfway between the wall and the center of the silo.

3.9 Inflowing Material

Do not mount the devices in or above the filling stream. The optimal position is as far away from the inflowing material.

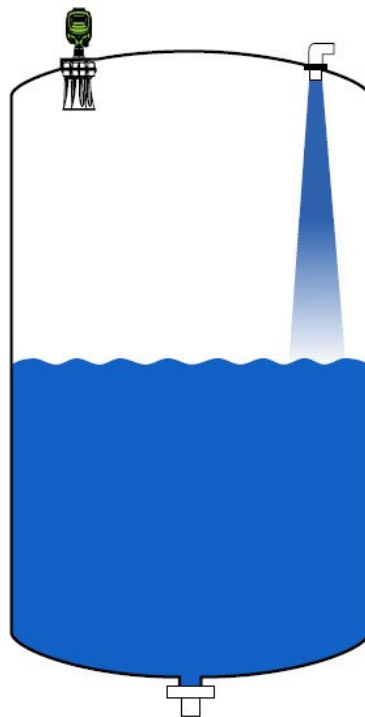

Figure 5: Inflowing material

4 Connections

Note on safety

Always observe the following safety instructions:

- Connect only in the complete absence of line voltage
- If overvoltages are expected, overvoltage arresters should be installed.
- A safety certified power supply which provides double insulation between the primary and output must be used for powering the unit. The power supply must be limited power source with output rating 20-32VDC, 1A.



In hazardous areas you should take note of the appropriate regulations, conformity and type of approval certificates of the sensors and power supply units.

4.1 General Requirements

The power supply range can differ depending on the device version. See the *Technical data, page 35*, for full details.

4.2 Power Supply

A safety certified power supply which provides double insulation between the primary and output must be used for powering the unit. The power supply must be limited power source with maximum output current 1A. The power supply voltage range should be 20 V DC minimum and 32 V DC maximum

- **4...20 mA/HART 4-wire**
Power supply and signal current are carried on two separate connection pairs of wires.

4.2.1 Connection Cable

- Use a 8...12 mm diameter cable to ensure the seal effect of the cable entry
- Conductor size of minimum 22AWG, Shielded Twisted Pairs of minimum of 2 pairs
- Suitable for application (indoor or outdoor) and safety certified according to national rules.

4.3 Connection procedure

1. Unscrew the back cover
2. Loosen the compression nut of the cable entry.
3. Remove approx. 10 cm (4 in) of the cable mantle, strip approx. 1 cm (0.4 in) insulation from the ends of the individual wires.
4. Insert the cable into the sensor through the cable entry.
5. Push the terminals top with a screwdriver (see following illustration).
6. Insert the wire ends into the open terminals according to the wiring plan.
7. Let go of the terminal top.
8. Check the hold of the wires in the terminals by lightly pulling on them.

9. Use a 16AWG cable for the ground cable to connect the screen to the internal ground terminal and the external ground terminal to potential equalization.
10. Tighten the compression nut of the cable entry. The seal ring must completely encircle the cable.
11. Screw the back cover back on.

4.4 Wiring Plans

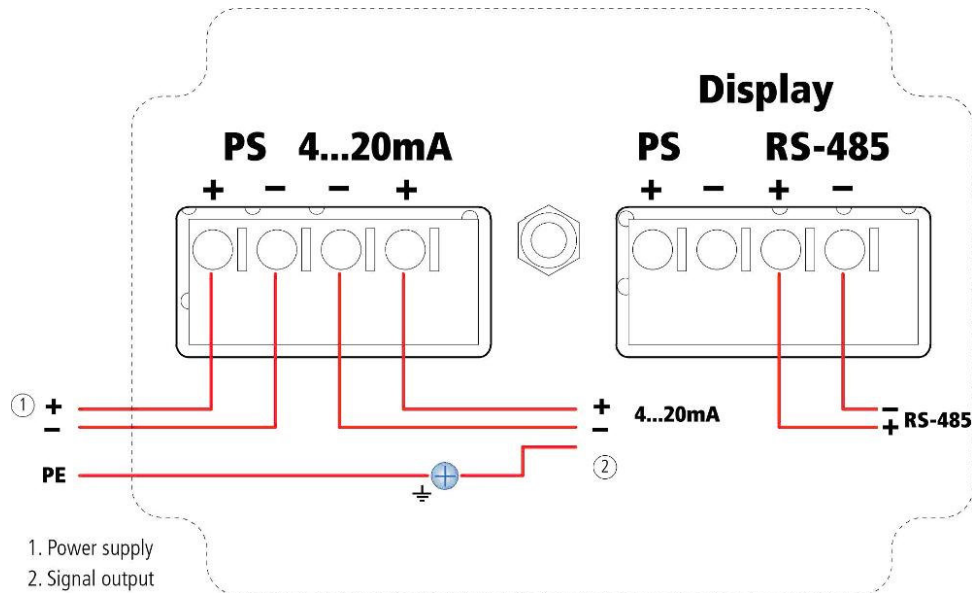

Figure 6: Connection Scheme

Left Connector	
Ports	Description
PS + -	Feed IN power supply 20...32 VDC
4..20mA - +	4..20 / HART communication connections

Right ("Display") Connector	
Ports	Description
PS + -	Feed OUT power supply 20...32 VDC
RS485 + -	RS485 / Modbus RTU communication connections



For more information about the connections, refer to "Different ways of connecting to 3DLevelScanner" document for additional help in connecting to the 3DLevelScanner using various interfaces (HART / RS485 / GSM / GPRS / Ethernet / Modbus).

5 Adjustment

The 3DLevelScanner S can be set up and operated using one of the following:

- An adjustment software tool (3DLevel Manager)
- GSM / GPRS communication using 3DLink Pro

5.1 3DLevelScanner S - LCD Panel



Figure 7: 3DLevelScanner S front panel LCD

Note: The 3DLevelScanner S can be adjusted but not configured with the LCD panel

Adjustment keys:



- Navigates downwards in the selection list
- Shifts to the right within a function



- Navigates upwards in the selection list
- Edit numeric values within a function



Navigates to the Left within a function group; Press **Esc** for 3 sec to go back to the default screen



- Navigates to the right within a function group;
- Confirmation

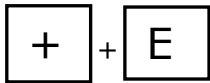

Simultaneously

Increases the contrast of the LCD

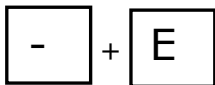

Simultaneously

Decreases the contrast of the LCD

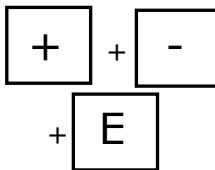

Simultaneously

Hardware lock/unlock

After a hardware lock, operation of the device via display or remote communication is not possible.

The hardware can only be unlocked via the display, and an unlock parameter must be entered to do so.

The display continues – uninterrupted.

When all three buttons are pressed the message “Hardware locked” is displayed.

When all three buttons are pressed again, the message “unlock parameter.” Appears. Enter the unlock parameter (100) and confirm by pressing E.

5.2 Adjusting the Scanner Using the Software Tool

The 3DLevelScanner S can be configured and operated via APM's Software Tool. Connect the 3DLevelScanner S according to the following diagram:

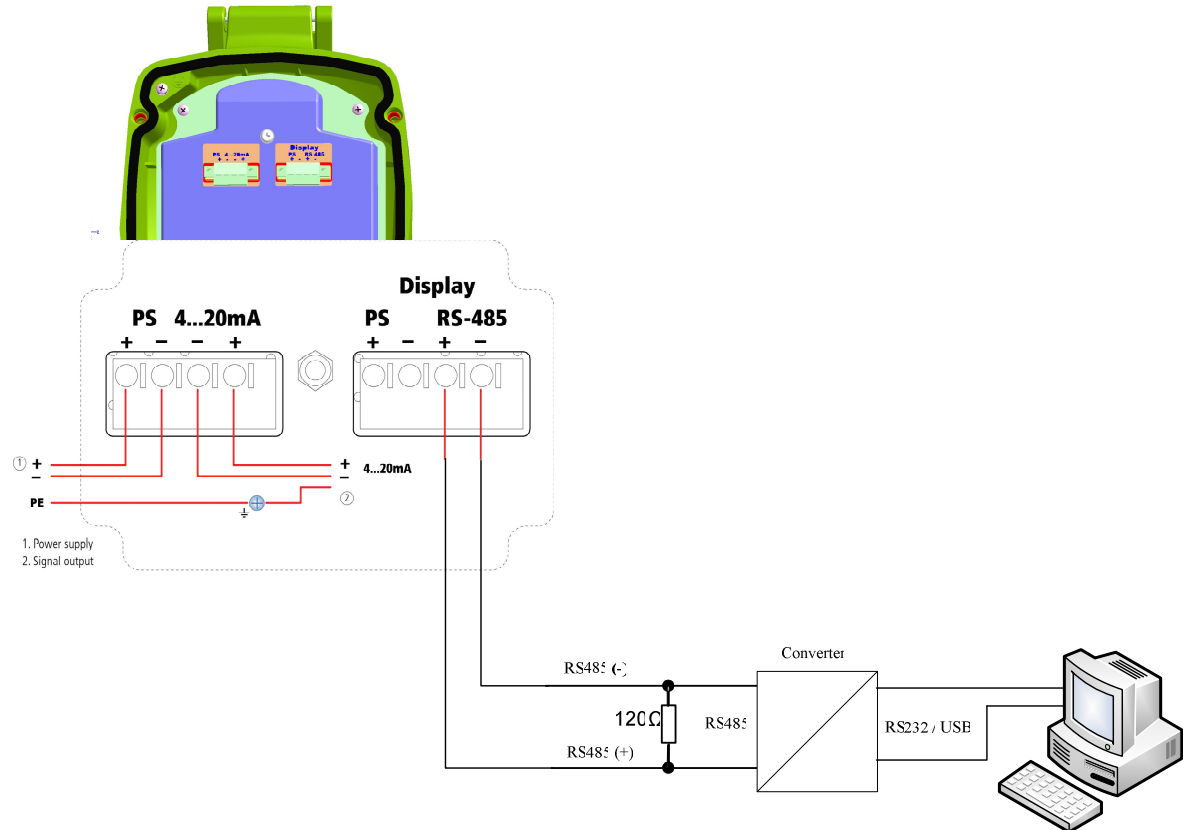

Figure 8: Software Tool connection

1. For specific instructions on adjusting parameters with APM's software tool, please see the *"APM 3DLevel Manager Software Operating Instructions"* manual.
2. The example above is an RS485 connection. There are more possibilities to connect to the 3DLevelScanner S using a different interface or protocol – for more help refer to *"Different ways of connecting to 3DLevelScanner"* manual.

6 Operation

6.1 Operating Menu

The operating menu consists of two levels:

1. **Function groups** (00, 01, 03, ..., 0C, 0D)
The device's functions are organized in function groups. The available function groups are: *basic setup, safety settings, output, display, system parameters, diagnostics, extended calibration, linearization, temperature.*
2. **Functions** (001, 002, 003, ..., 0D8, 0D9)
Each function group consists of one or more functions. The functions perform actions or set up the device's parameters. Numerical values can be entered and parameters can be selected and saved. The available functions of the *basic setup* function group (00) include: *media type (002), process cond. (004), empty calibr. (005), etc.*

For example, if you wish to change the media type, do the following:

- Select the *basic setup (00)* function group.
- Select the media type (002) function (where the existing media type is selected).

6.2 Function indication

A three digit identifier is displayed on the right-hand side of the function on the display. The first two digits identify the function group. The third digit indicates the individual function within the function group.

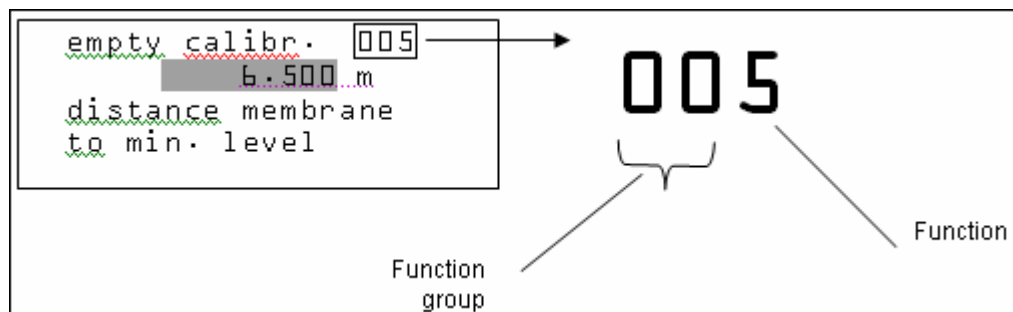

6.3 Switching on

After 3DLevelScanner S is connected to the power supply, it carries out a self-test for approx. 30 seconds. After the initialization is complete, the following is displayed, allowing you to select a language and distance units.

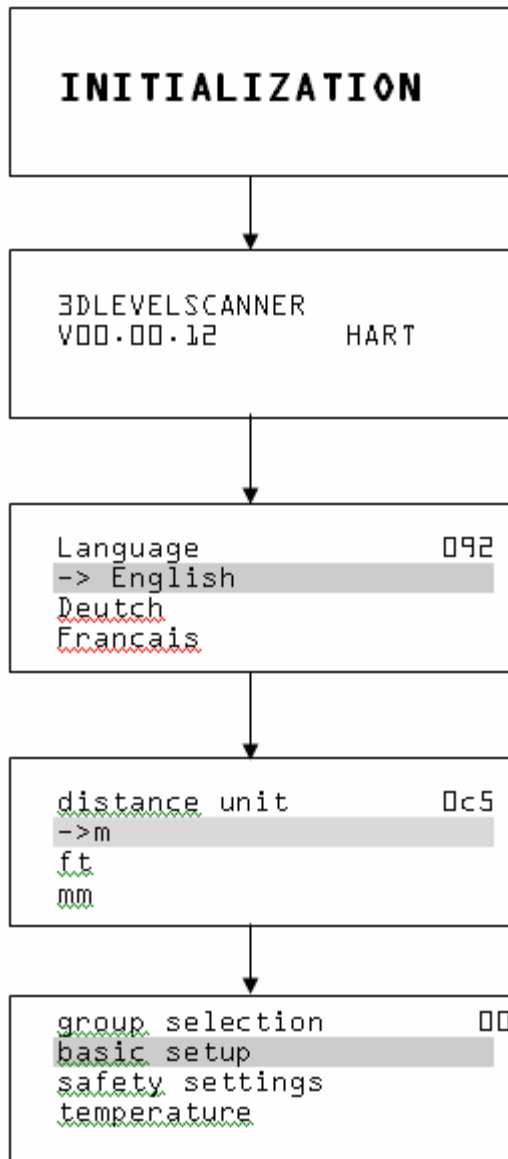

After 30 seconds, the following message appears:

Vxx.yy.zz Prot.

xx – hw version

yy – sw version

zz – sw version

prot – HART (Protocol name)

After five seconds or after pressing , you will be presented with language selection: (appears on the first time the device is switched on): Use the +/- to select the desired language and press .

Select the distance units (this selection appears on the first time the device is switched on)

Press to reach the group selection. This selection enables you to perform the basic setup.

6.4 Basic/Default Screen

After startup the following screen is displayed:

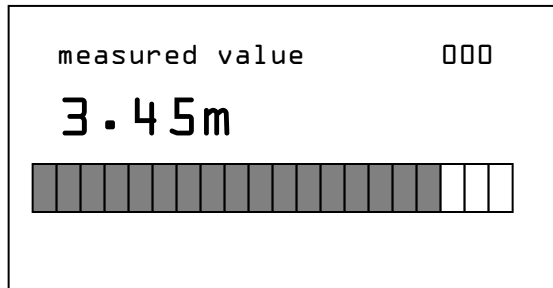

Press  to reach the group selection menu.

Press  for 3 seconds to return to the measured value basic screen

6.5 Setup procedure

6.5.1 Address setting for several sensors on one input – RS485-Multidrop (Daisy Chain)

If several sensors are connected on one input, the address must be set before continuing with parameter adjustment. This is done in RS485-Multidrop mode. For detailed description please see the "Description of Instrument Functions" manual.

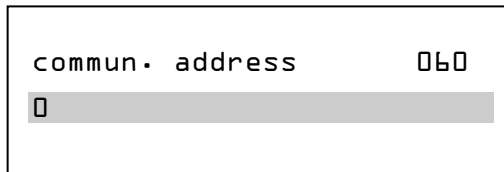

Enter the polling address for the device with this function.

- Default: 0
- Multidrop: 1-64

6.5.2 Parameter adjustment

Because the 3DLevelScanner S is primarily a distance measuring device, the distance from the sensor to the product surface is measured. In order to have the actual product level displayed, an allocation of the measured distance to the height percentage must be carried out. To make this adjustment, the full and empty distances in the vessel are entered. The seal surface of the thread or flange is always the reference point for these distance values. The actual level is then calculated on the basis of the entered values. At the same time, the operating range of the sensor is limited from maximum range to the required range.

The actual product level during this adjustment is not important, because the min./max. adjustments are always performed without changing the product level. These settings can be made in advance without having to install the device first.

The individual submenu items in the main menu item "*Basic adjustment*" should be selected one by one and updated with the correct parameter values.

Start your parameter adjustment with the following menu items of the basic adjustment.

6.5.3 Medium selection

Each product has different reflective properties. In solids, they are determined by dust generation, material cones and additional echoes caused by the vessel wall. Selecting the correct medium will ensure optimal adaptation of the sensor to the product and significant increase in accuracy, particularly for products with bad reflective properties.

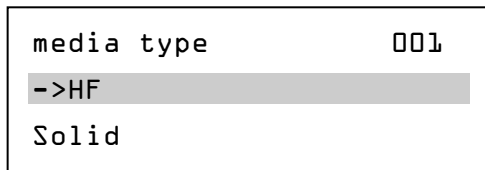

This function is used to select the media type:

- HF
- Solid
- Solid SA

Enter the requested parameter via the appropriate keys, save your settings and move on to the next menu item with the **[E]** key.

6.5.4 Process Conditions

The process conditions are another factor that influences the measurement. To adapt the sensor to the process conditions, this menu offers several options.

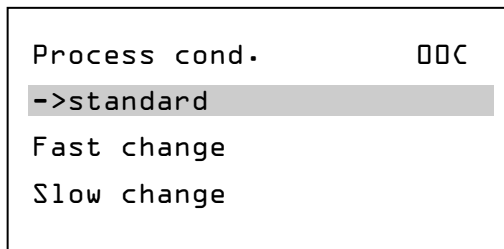

Enter the requested parameter via the appropriate keys, save your settings and move on to the next menu item with the **[E]** key.

6.5.5 Performing empty calibration adjustment

1. Move from the measured value display to the main menu by pressing **[E]**.

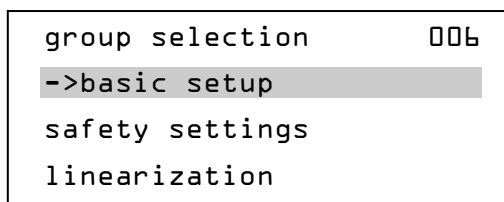

2. Select the *Basic setup* menu with **[->]** and confirm with **[E]**. Now select the Empty Calibr. with **[->]** and confirm with **[E]**. The "Empty calibr." menu is displayed.

```

empty calibr.      005
b.500 m
distance flange
to min. level

```

This function is used to enter the distance from the flange (reference point of the measurement) to the minimum level (=zero).

Enter the requested parameter via the appropriate keys, save your settings and move on to the next menu item with the **[E]** key.

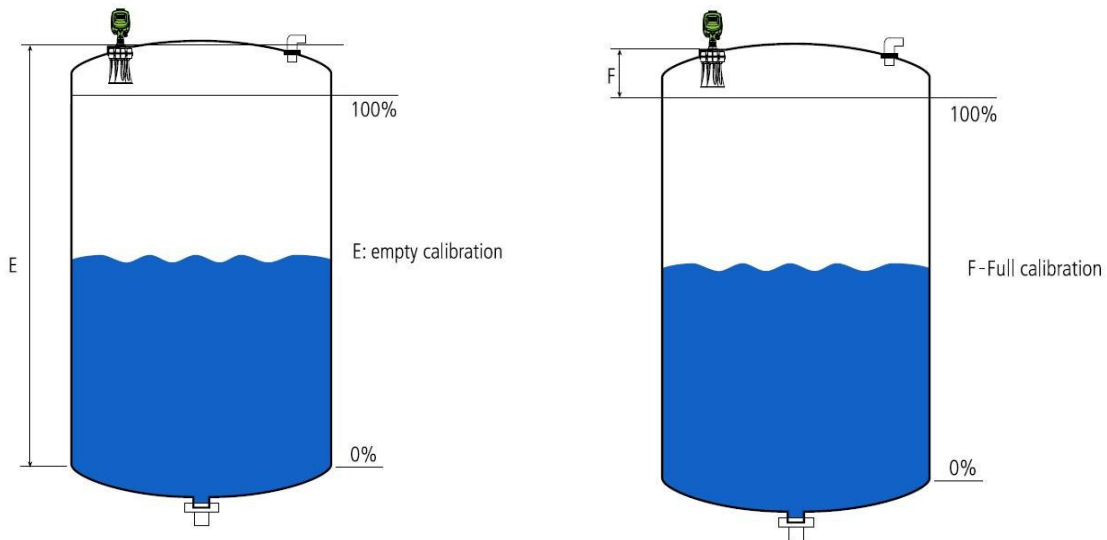

Figure 9: Empty and Full Calibration

3. Enter the appropriate distance value in DU (corresponding to the percentage value) for the empty vessel (e.g., distance from the sensor to the vessel bottom).
4. Save the settings by pressing **[E]** and move on to "Full Calibr".

6.5.6 Performing Full Calibration adjustment

Proceed as follows:

```
full calibr.          006
└─.75m
distance flange
to max. level
```

This function is used to enter the distance from the bottom of flange (measurement reference point) to the maximum level (100%).



CAUTION!

The maximum level may not project into the blocking distance (BD). If the BD is compromised, it may cause device malfunction. After basic calibration, enter a safety distance (SD) in the safety distance (015) function. If the level is within this SD, the 3DLevelScanner S signals a warning or an alarm, depending on your selection in the 'in safety distance' (016) function.

1. Enter the appropriate distance value in m and save with **[E]**.
2. Save the settings with **[E]**

At this point, the basic adjustment is complete.

7 False echo storage

High sockets or vessel installations, such as struts or agitators as well as buildup and weld joints on the vessel walls, cause interfering reflections which can impair the measurement. False echo storage detects and marks these false echoes, so that they are no longer taken into account in level measurement. A false echo memory should be created with an empty vessel so that all potential interfering reflections will be detected.

7.1 Range of mapping function (052)

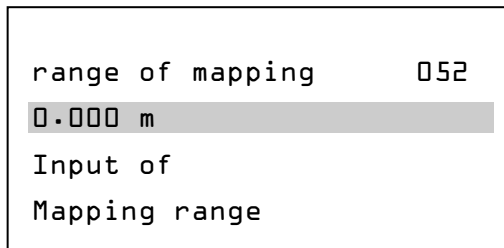

This function displays the suggested range of mapping. The reference point is always the reference point of the measurement (see Function 005). This value can be edited by the operator for manual mapping. The default value is 0 m.

CAUTION!

The range of mapping must end 1 m before the echo of the actual level. For an empty vessel, do not enter E, but E - 1 m. If a mapping already exists, it is overwritten up to the distance specified in the range of mapping (052). Beyond this value the existing mapping remains unchanged.

8 Optional settings

Additional adjustment and diagnosis options such as scaling and simulation are shown in the following menu diagrams. You will find a detailed description of these menu items in the "3DLevel Manager Software Operating Instructions" manual.

All the menus and submenus in the LCD exactly match the menus in the 3DLevel Manager software. It is preferable and more comfortable to make all the configurations in the 3DLevel Manager after mounting and connecting the unit.

For more information of how to connect to the 3DLevelScanner refer to the "*Different ways of connecting to 3DLevelScanner*" manual.

8.1 Basic/default displayed screen

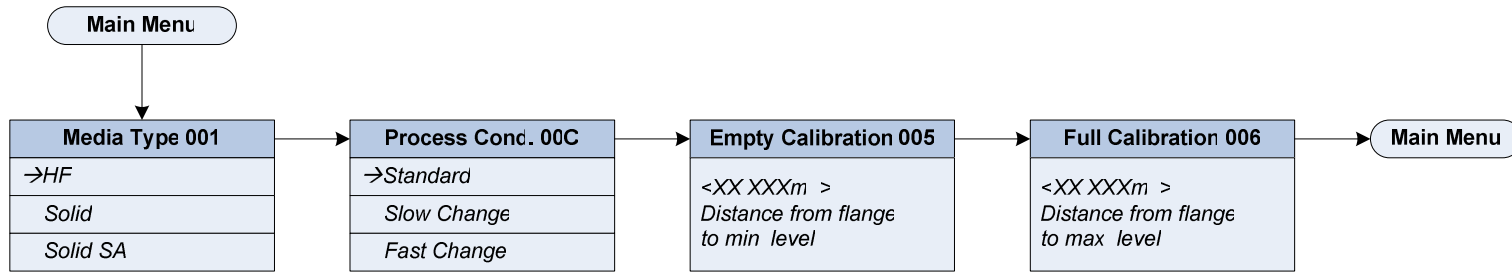

8.2 Linearization screen

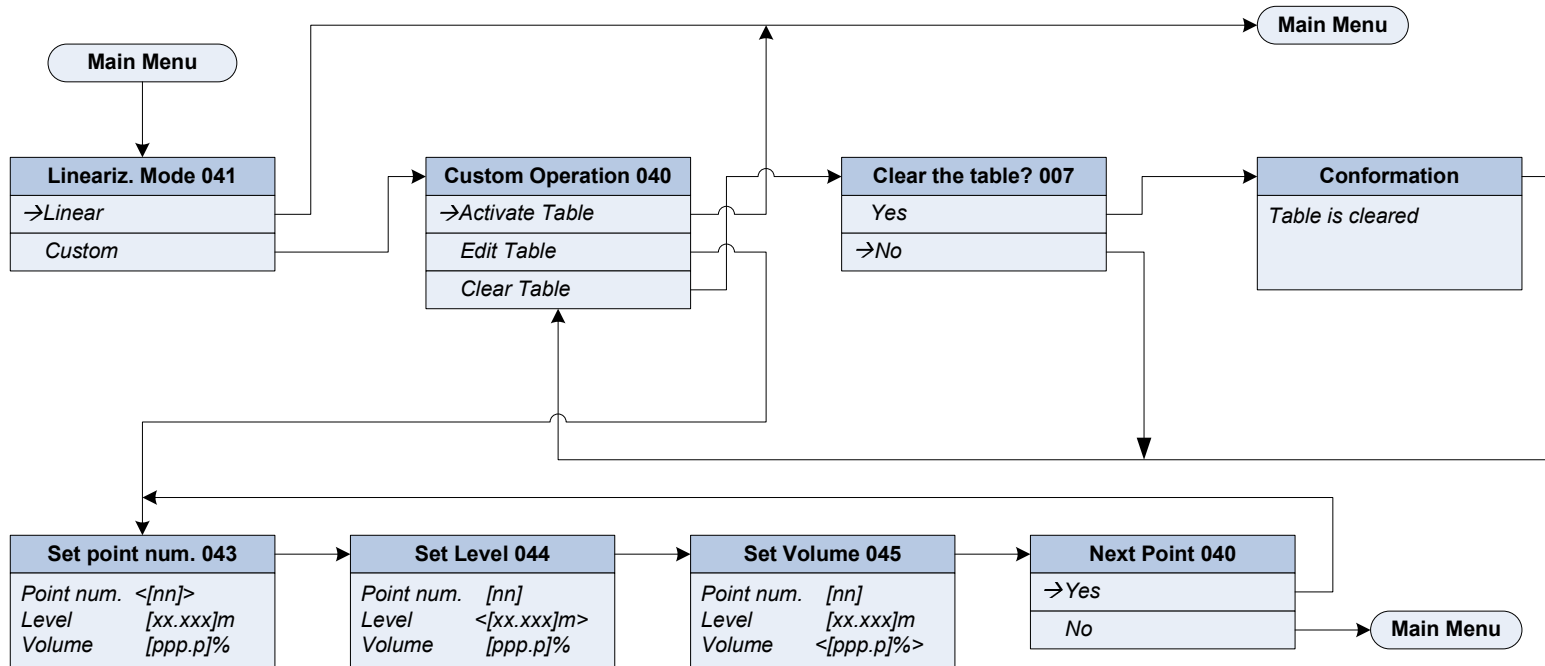

8.3 Extended calibration screen

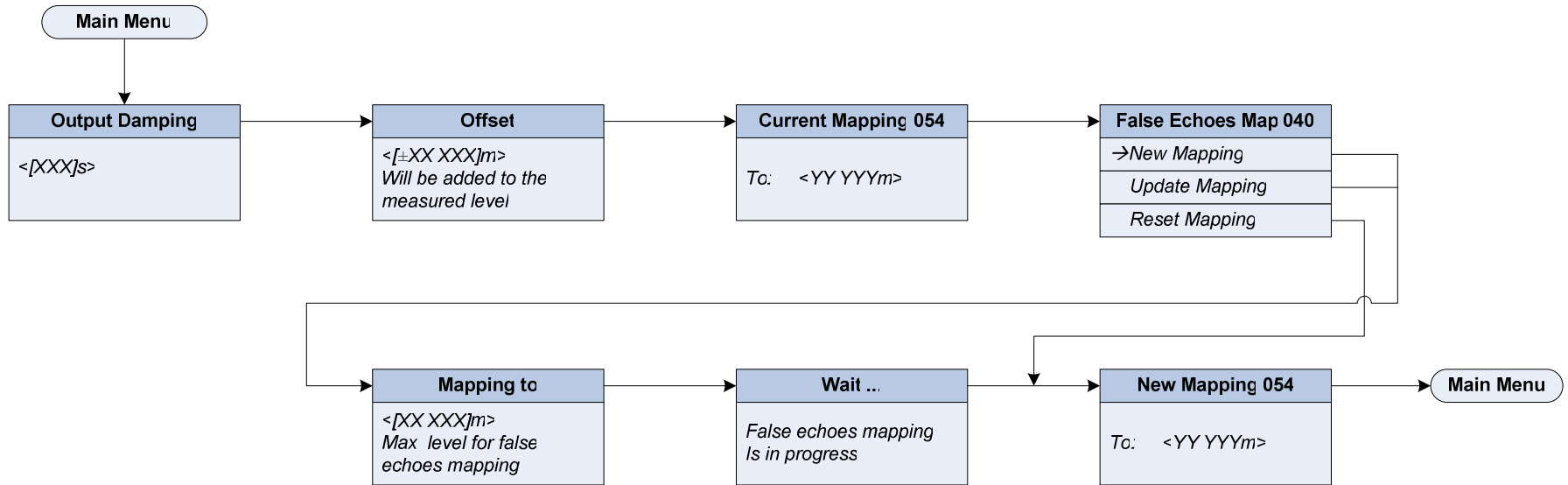

8.4 Output screen

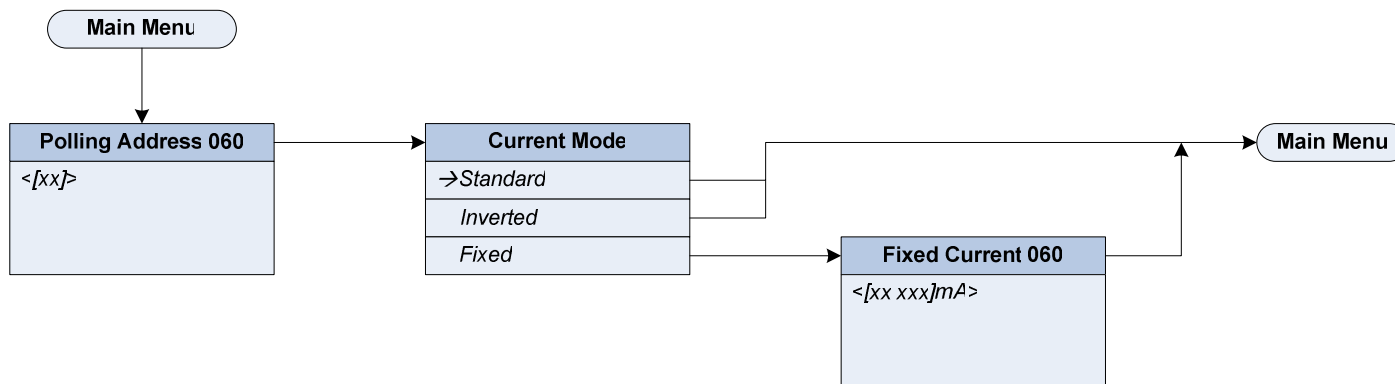

8.5 Display screen

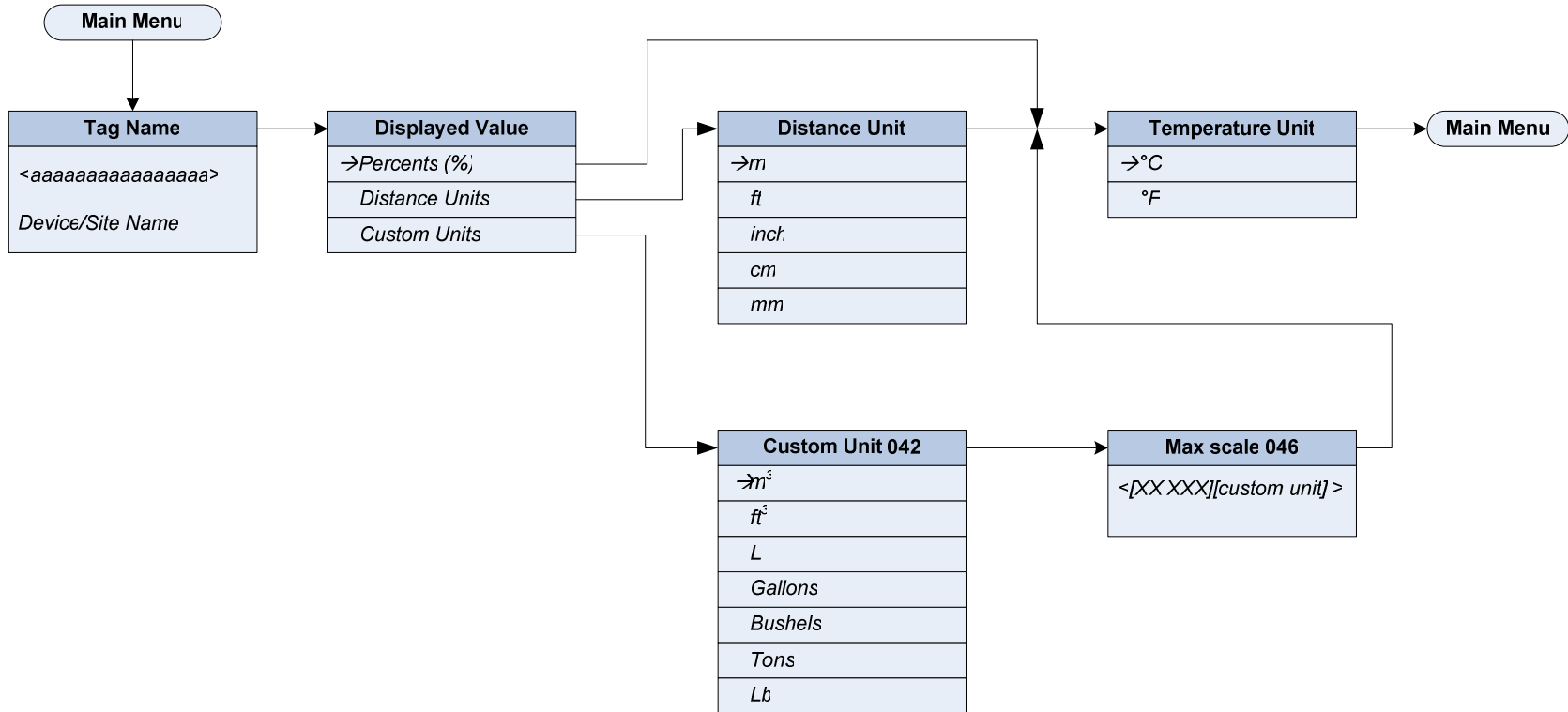

8.6 Measured Parameters

Min / Max values will be displayed in M/MV versions only

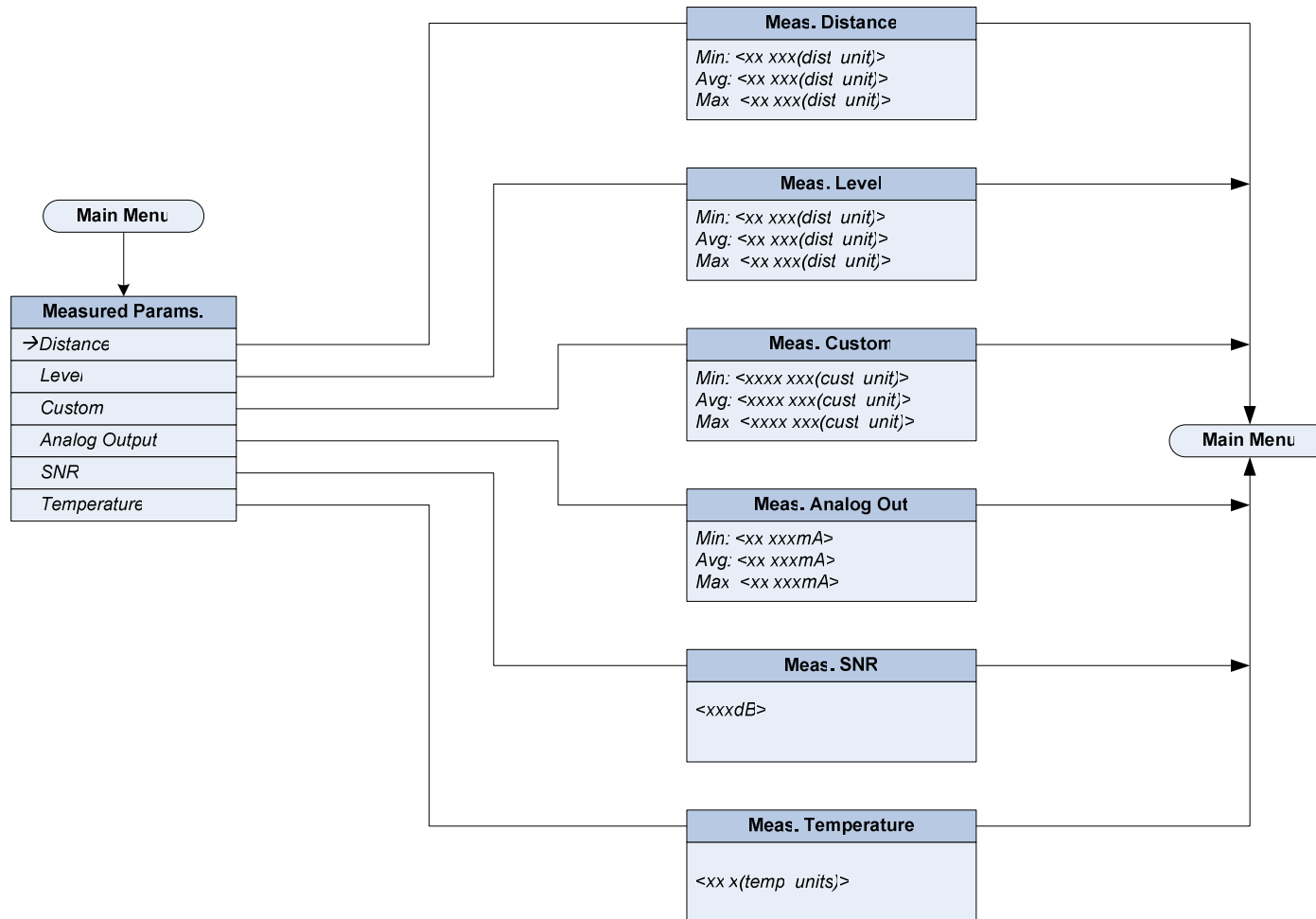

8.7 Device Info

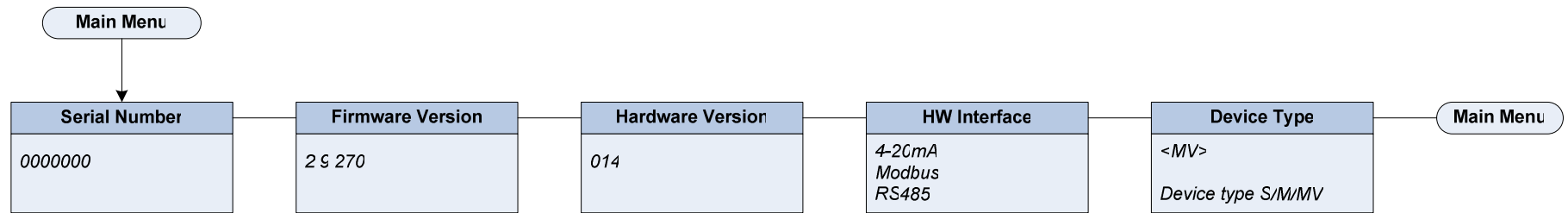

8.8 Device Reset

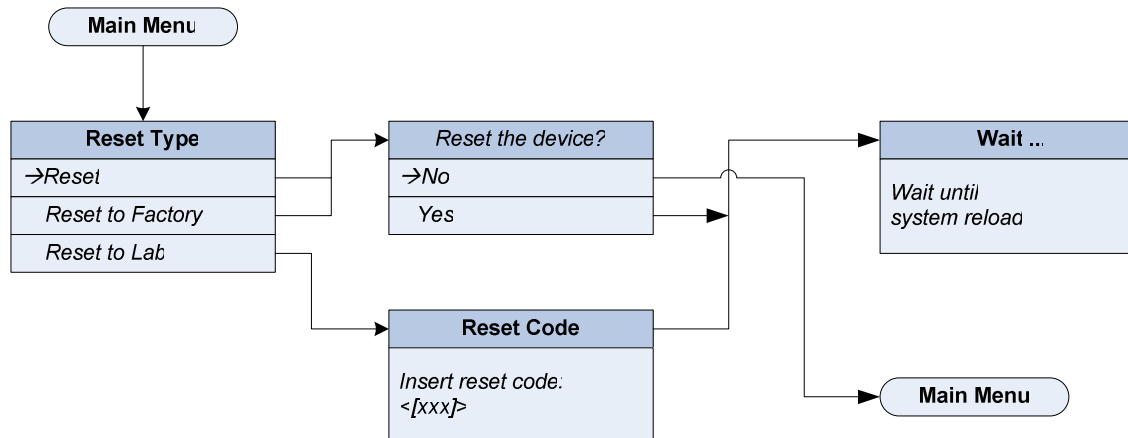

9 Maintenance and fault rectification

9.1 Maintenance

When used as directed in normal operation, the 3DLevelScanner S is completely maintenance-free.

9.2 Fault rectification

Causes of malfunction

The 3DLevelScanner S is highly reliable. Nevertheless, faults can occur during operation. Faults may be caused by the following:

- Sensor
- Process
- Power supply
- Signal processing.

The first measures to be taken are to check the output signal and evaluate the failure messages via the LCD. The procedure is described below. More comprehensive diagnostics can be performed by connecting the scanner to the 3DLevel Manager and using the BIT in the diagnostic group (in the *APM 3DLevel Manager software operating instructions*). In many cases the fault reasons can be determined and rectified using this method.

9.2.1 24 hours support

If you fail to solve the problem with the methods suggested here, please contact APM Customer Support.

The service is available 7 days a week around the clock. Since we offer this service world-wide, the support is only available in the English language.

9.2.2 Checking the 4 ... 20 mA signal

Connect a hand-held multimeter with a suitable measuring range according to the wiring plan.

? 4 ... 20 mA signal not stable

Possible Problem: level fluctuation

Solution: set integration time via LCD or APM's Software.

? 4 ... 20 mA signal missing.

Possible Problem: incorrect connections

Solution:

Check connection according to *Connection Procedure, page 13*, and correct, if necessary, according to the wiring plan, see *Wiring Plans, page 14*.

Possible Problem: No power supply

Solution: Check cables for line break, repair if necessary.

Possible Problem: Supply voltage too low or load resistance too high

Solution: Check and adapt, if necessary.

? Current signal greater than 22 mA or less than 3.6 mA

Possible Problem: Electronics module defective

Solution: Exchange device or return it for repair.

9.3 Replacing the electronics

If the electronics module is defective, it can be replaced by the user.

If there is no electronics module available on site, it can be ordered from your local APM agency.

9.4 Device repair

If it is necessary to repair the 3DLevelScanner please proceed as follows:

Download a return form from our Web site www.apm-solutions.com, under "*Services – RMA Request Form*".

By doing this you help us carry out the repair quickly and without having to call back for additional information.

- Print and fill out one form per device.
- Clean the device and pack it damage-proof.
- Attach the completed form and optionally a safety data sheet to the device.
- Send the device to the address of your local agency.

10 Dismounting

10.1 Dismounting procedure



Warning!

Before dismounting, be aware of dangerous process conditions such as pressure in the vessel, high temperature, corrosive or toxic products etc.

Take note of the chapters *Mounting, page 8*, and *Connections, page 13* and carry out the listed steps in reverse order.

We have specifically designed the electronic modules to be easily separable. Mark the device as scrap and dispose of it according to government regulations (electronic scrap ordinance).

If you cannot dispose of the device properly, please contact us about disposal methods, or return.

11 Dimensions

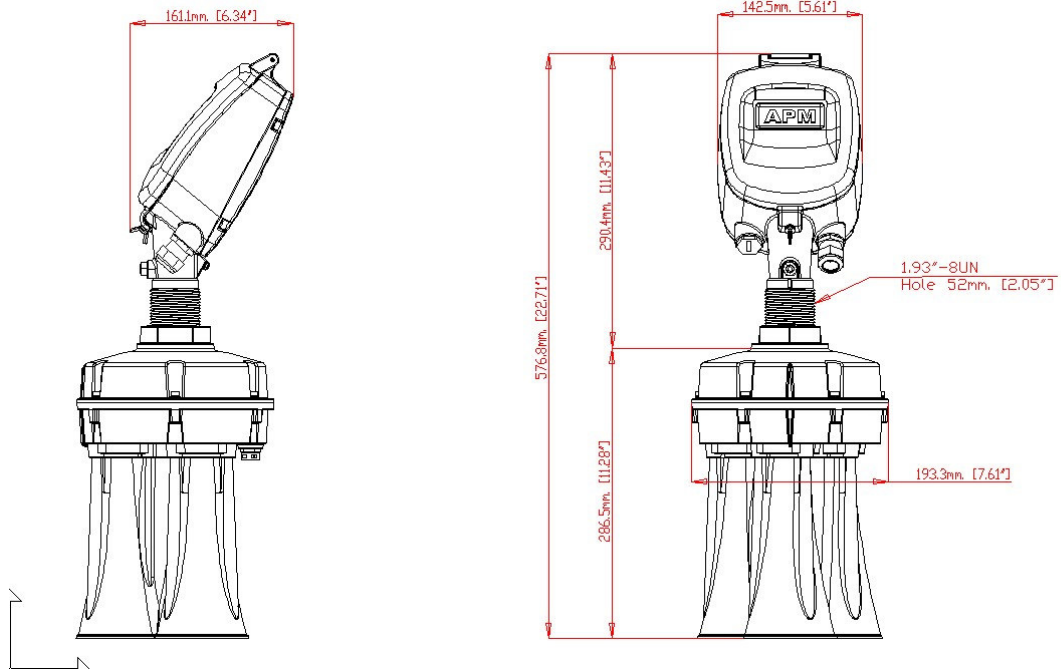

Figure 10: 3DLevelScanner S with horn antenna in threaded version

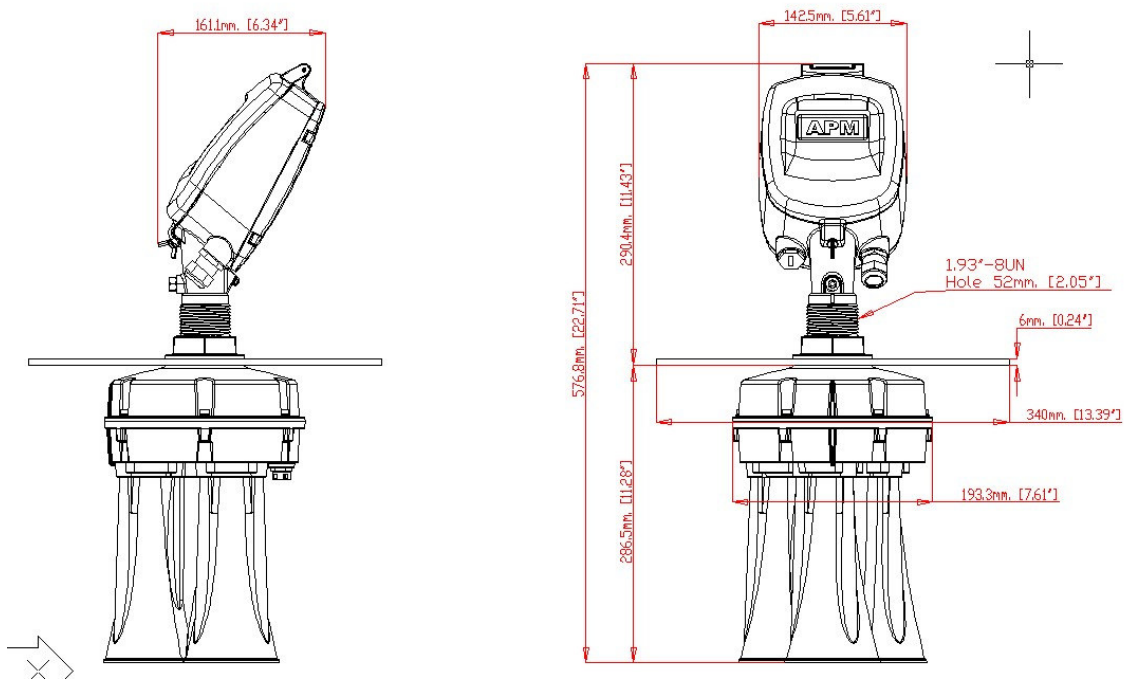

Figure 11: 3DLevelScanner S with horn antenna in flange version

Dimensions are in mm (inch).

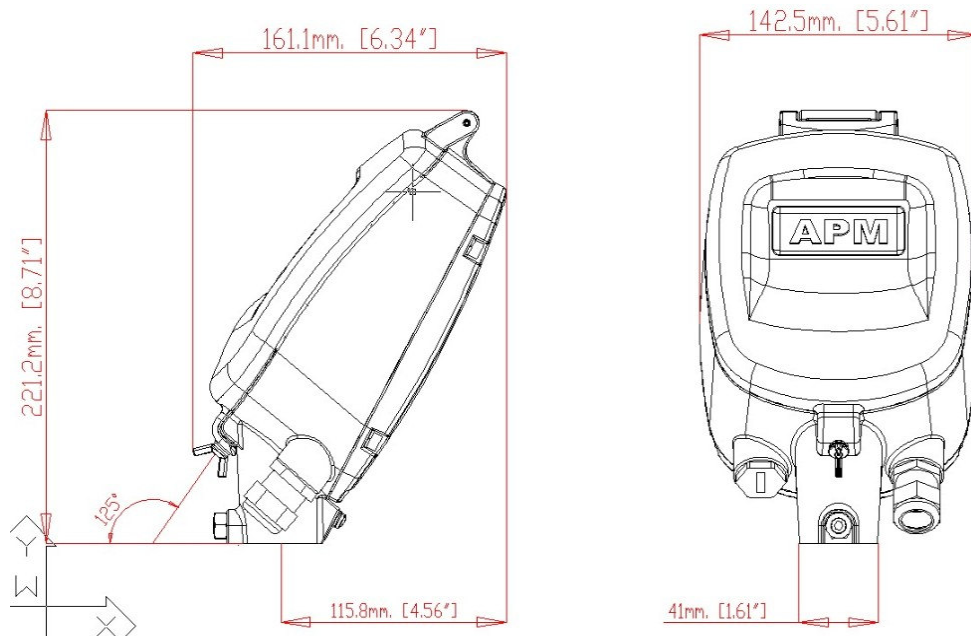

Figure 12: 3DLevelScanner S housing

Dimensions are in mm (inch).

12 Appendix

12.1 Technical data

Materials, non-wetted parts

Housing	Painted Aluminum die casting
Inspection window in housing cover	Polycarbonate
Antenna	Painted Aluminum die casting
Ground terminal	Stainless steel 1.4571/1.4435

Weight

5.6 kg

Output variable

Output signal	4...20mA/HART/RS485/Modbus
Resolution	10 uA
Fault signal	Current output unchanged, 22mA, >3.6 mA (adjustable)
Current limitation	22mA

Load

4-wire sensor	See load diagram
Integration time	0...9999 s, adjustable

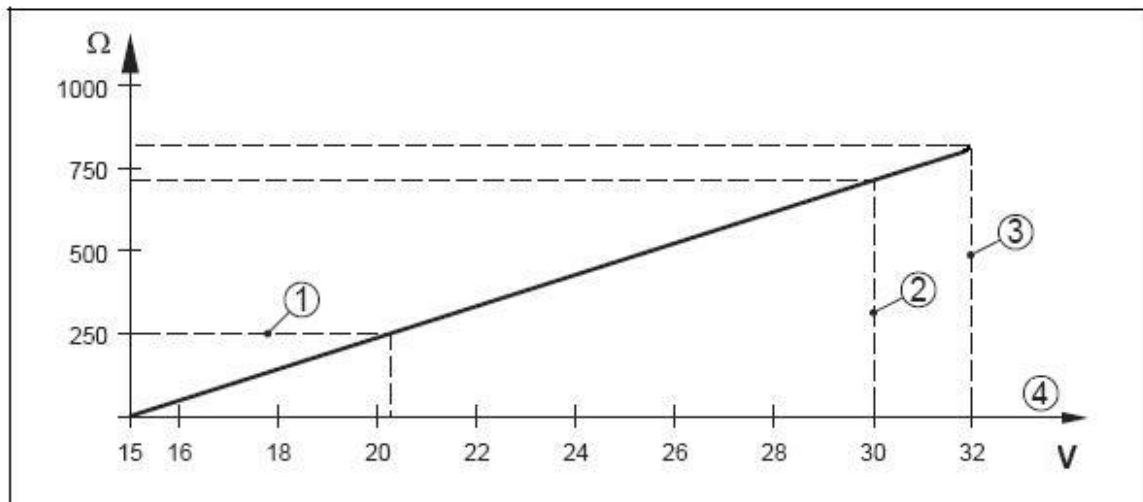

Figure 13: Voltage diagram

1. HART Load
2. Voltage Limit EEx ia device
3. Voltage limit non-Ex/Exd ia device
4. Supply Voltage

12.2 Ambient conditions

Ambient, storage and transport temperature: -40...85°C (-40...+185°F)

Relative humidity 20...85%

Altitude of 5,000m (16,400ft)

12.3 Process conditions

Vessel pressure: -0.2 ... 1 bar
(-20...100 kPa or -2.9 ... 14.5 Psi)

12.4 Process temperature

Measured on the process fitting: -40...85°C (-40...185°F)

Vibration resistance: Mechanical vibrations with 2g and 5...200 Hz

12.5 Electromechanical data

Cable entry/plug: 1 x cable entry M20x1.5 (cable-Ø 8...12mm with conductor size of 22AWG, preferable shielded twisted pairs type cable), 1 x blind stopper M20x1.5

or

2 x cable entry ½NPT

Display panel

LCD	4 lines x 20 characters
Adjustment elements	4 keys
Protection	IP67

Power supply – 4-wire device

A safety certified power supply which provides double insulation between the primary and output must be used for powering the unit. The power supply must be limited power source with maximum output current 1A. The power supply voltage range should be 20 V DC minimum and 32 V DC maximum

4...20 mA/HART

Supply voltage	20...32 VDC
Power consumption	max 4VA; max 3W

Electrical protective measures

Protection	IP 67 according to IEC 60529
------------	------------------------------

Approvals

ATEX	ATEX II ½D, 2D, Ex ibD/iaD 20/21 T110°C ATEX II 2G Ex ia/ib IIB T4
FM	FM Intrinsic safety CL II, DIV I, GP EFG
CSA	CSA Intrinsic safety (pending)
IECEX	IEC EEx ia IIC T6 (pending)

CE

EMC (2004/108/EC)

- Emission EN 61326: 1997 (class B)
 - Susceptibility IEC / EN 61326:1997 + A1: 1998 + A2:2001 + A3:2003
- NSR (73/23/EWG) EN 61010-1: 2001

FCC

Conformity to part 15 of the FCC regulations
FCC 47 CFR part 15:2007, subpart B, class A

The 3DLevelScanner complies with Part 15 of the FCC Rules. Operation is subject to the following two conditions: (1) this device may not cause harmful interference, and (2) this device must accept any interference received, including interference that may cause undesired operation.

Measurement characteristics

- Frequency 3-10 kHz
- Beam angle with horn antenna 30 degrees
- Interval >2 s (dependent on the parameter adjustment)
- Adjustment time >3 s (dependent on the parameter adjustment)

Accuracy (see diagram)

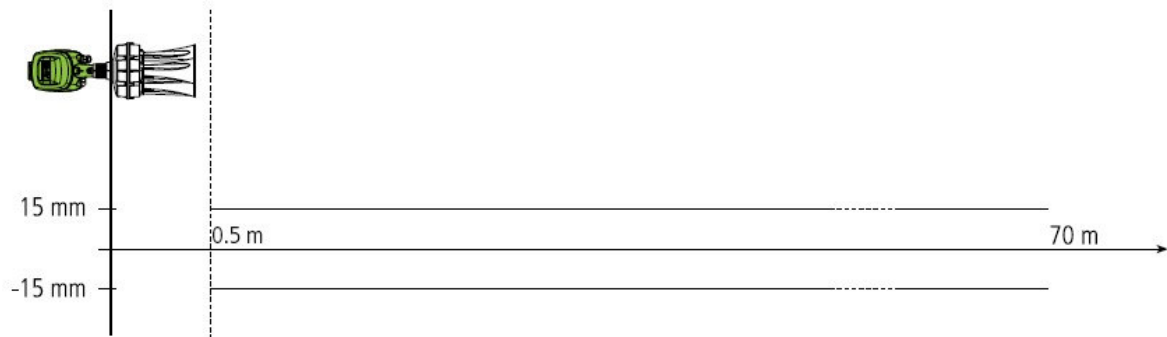

Figure 14: Accuracy

OPERATING INSTRUCTIONS

You can find at

www.apm-solutions.com

downloads of the following:

- **Brochures**
- **Data Sheets**
- **Operating instructions manuals**
- **Software**
- **Certificates**
- **Product information**

and much, much more



APM Automation Solutions Ltd

24 Habarzel Street
Tel Aviv 69710, Israel
Tel: +972 3 6488891
Fax : +972 3 6488892
info@apm-solutions.com
www.apm-solutions.com

Represented by

MAN0000250 Rev. 03



© 2006 A.P.M. Automation Solutions Ltd. All rights reserved. Information in this document is subject to change without notice. A.P.M. Automation Solutions Ltd. and the APM 3DLevelScanner are trademarks of A.P.M. Automation Solutions Ltd.